

PRODUCT CATALOGUE :

ASW SECTIONS

900 SERIES

SLIDING DOOR SECTIONS

YC SECTIONS

SCREEN DOOR AND
WINDOW SECTIONS

LYC SECTIONS

SWING DOOR SECTIONS

CLEO SECTIONS

MULLION SECTIONS

STOREFRONT SECTIONS

MINI MULLION SECTIONS

ANGLE SECTIONS

Y - SECTIONS

FLAT BAR SECTIONS

VENTILATION SECTIONS

SQUARE BAR SECTIONS

38 SERIES

ROUND BAR SECTIONS

50 SERIES

COUNTER TRIM SECTIONS

798 SERIES

U - CHANNEL SECTIONS

BFPI SECTIONS

SPECIAL SECTIONS

SENZA SECTIONS



ASW SECTIONS

TELS.No.7586 - 8309 ,
8990 - 7364
CP.No. 09171838309
FAX.No. 8983 - 2732

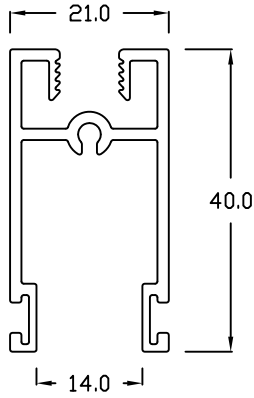

ASW - 4
BOTTOM RAIL

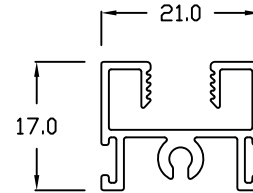

ASW - 5
TOP RAIL

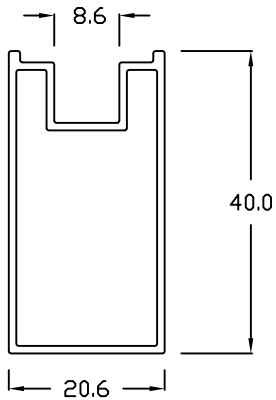

ASW - 6
LOCKSTILE

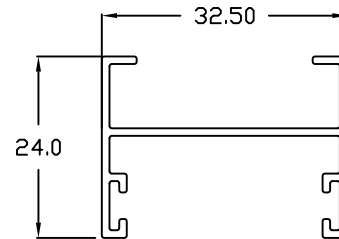

ASW - 8
ASTRAGAL

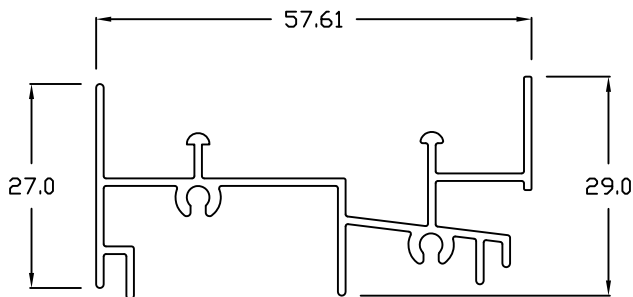

ASW - 13
DOUBLE SILL

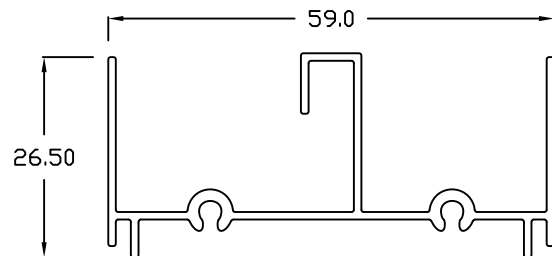

ASW - 14
DOUBLE HEAD



ASW SECTIONS

TELS.No.7586 - 8309 ,
8990 - 7364
CP.No. 09171838309
FAX.No. 8983 - 2732

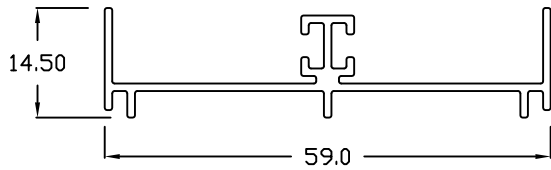

ASW - 15
DOUBLE JAMB

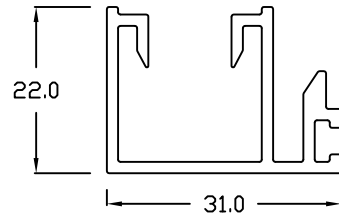

ASW - 17
INTERLOCKER

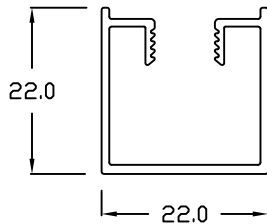

ASW - 18
FIXED STILE

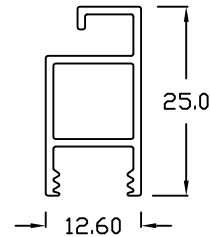

ASW - 21
SCREEN FRAME

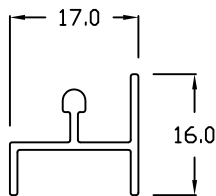

ASW - 22
SCREEN SILL

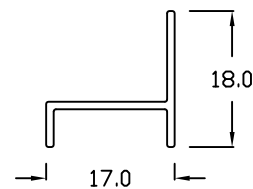

ASW - 23
SCREEN HEAD JAMB



SLIDING DOOR SECTIONS

TELS.No.7586 - 8309 ,
8990 - 7364
CP.No. 09171838309
FAX.No. 8983 - 2732

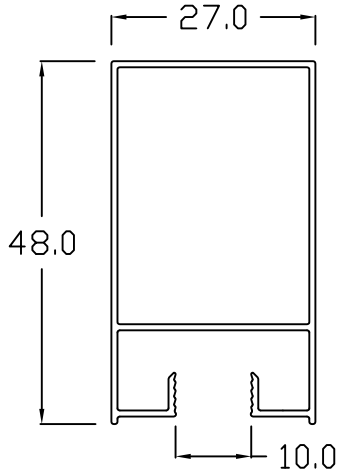

**SD - 103
LOCKSTILE**

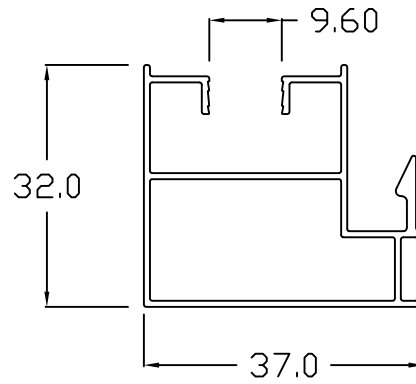

**SD - 104
INTERLOCKER**

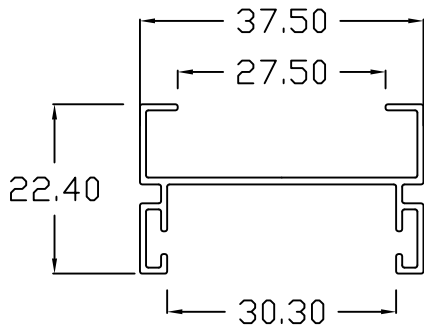

**SD - 106
ASTRAGAL**

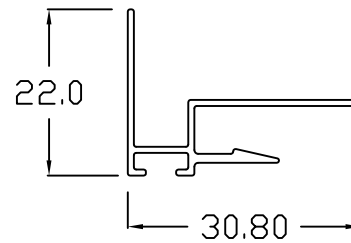

**SD - 107
POCKET INTERLOCKER**

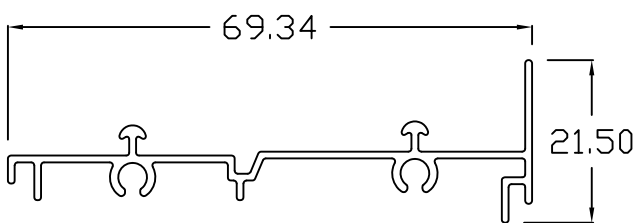

**SD - 131
DOUBLE SILL**

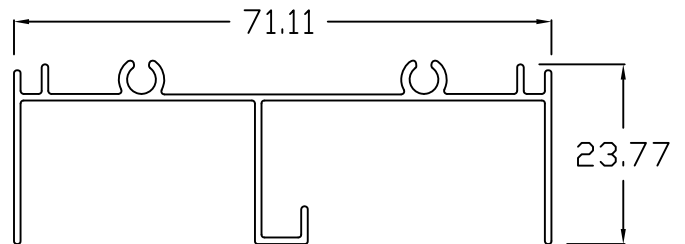

**SD - 132
DOUBLE HEAD**



SLIDING DOOR SECTIONS

TELS.No.7586 - 8309 ,
8990 - 7364
CP.No. 09171838309
FAX.No. 8983 - 2732

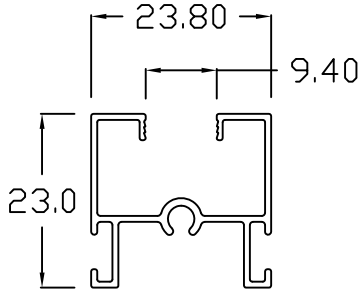

**SD - 133
TOP RAIL**

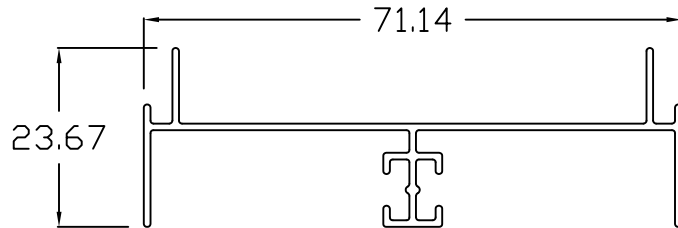

**SD - 134
DOUBLE JAMB**

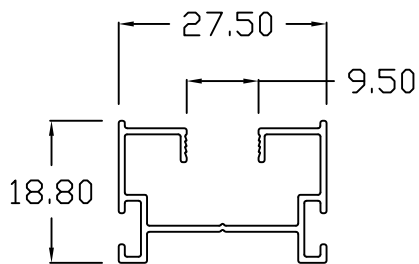

**SD - 135
FIXED STILE**

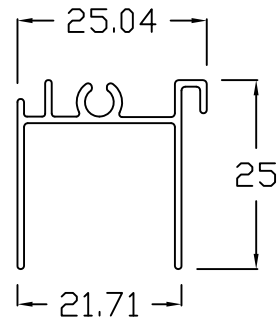

**SD - 137
SCREEN HEAD**

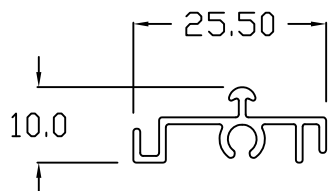

**SD - 138
SCREEN SILL**

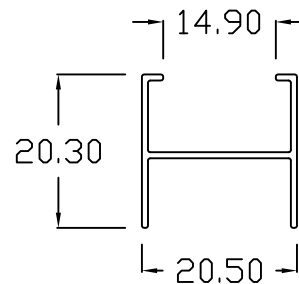

**RPC 12149
SCREEN ASTRAGAL**



SLIDING DOOR SECTIONS

TELS.No.7586 - 8309 ,
8990 - 7364
CP.No. 09171838309
FAX.No. 8983 - 2732

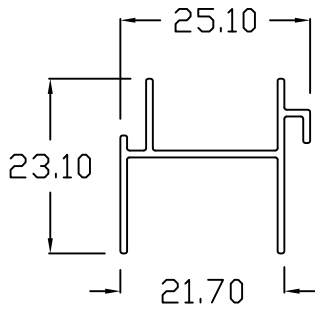

SD - 140
SCREEN JAMB

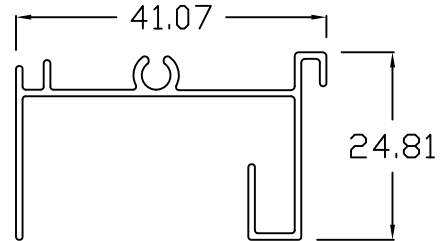

SD - 141
SINGLE HEAD

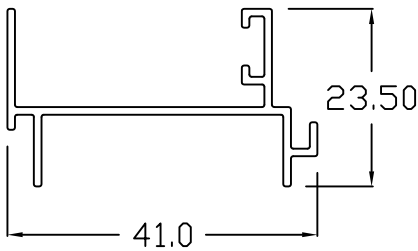

SD - 142
SINGLE JAMB

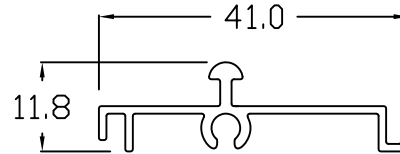

SD - 143
SINGLE SILL

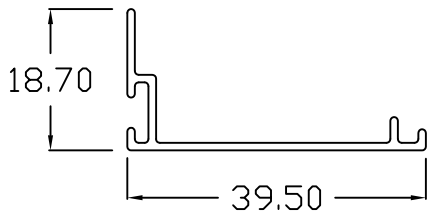

SD - 144
STEP SILL

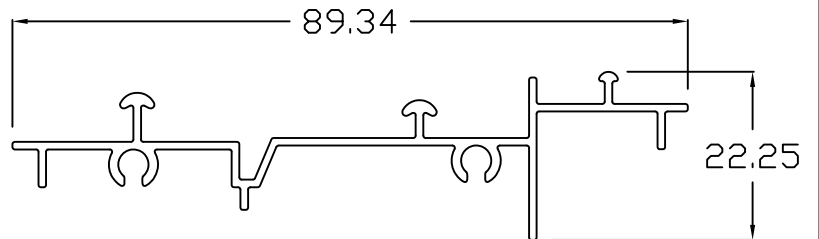

SD - 145
DOUBLE SILL W/ SCREEN



SLIDING DOOR SECTIONS

TELS.No.7586 - 8309 ,
8990 - 7364
CP.No. 09171838309
FAX.No. 8983 - 2732

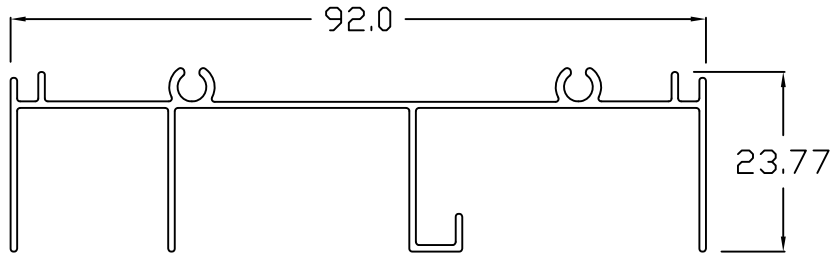

SD - 146

DOUBLE HEAD W/ SCREEN

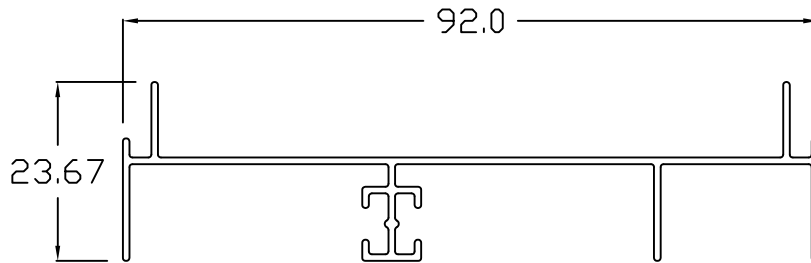

SD - 147

DOUBLE JAMB W/ SCREEN

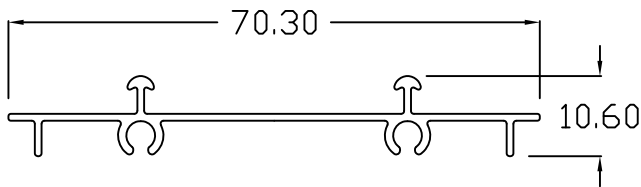

SD - 149

DOUBLE FLAT SILL

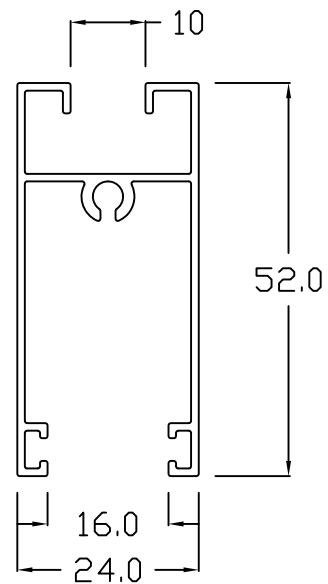

SD - 204

BOTTOM RAIL



SCREEN DOOR AND WINDOW SECTIONS

TELS.No.7586 - 8309 ,
8990 - 7364
CP.No. 09171838309
FAX.No. 8983 - 2732

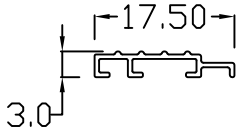

SF - 750S
SCREEN FRAME 3/4 S/C

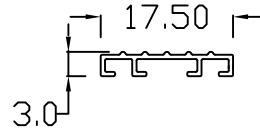

SF - 750D
SCREEN FRAME 3/4 D/C

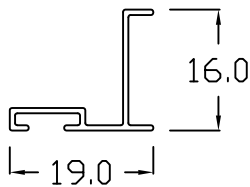

JW - 6105
BUMPER

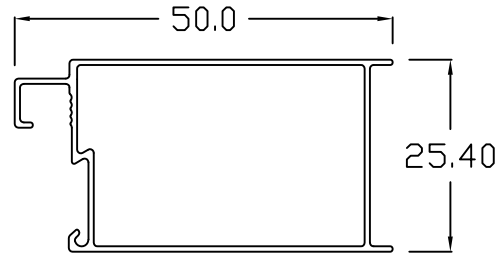

SF - 101
SCREEN DOOR FRAME

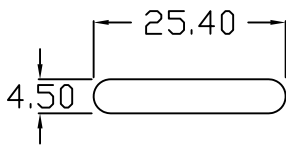

SF - 101PB
PUSH BAR 3/16

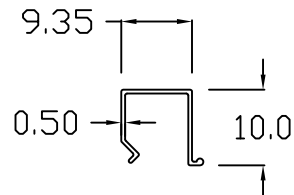

SF - 102
CLIP



SCREEN DOOR AND WINDOW SECTIONS

TELS.No.7586 - 8309 ,
8990 - 7364
CP.No. 09171838309
FAX.No. 8983 - 2732

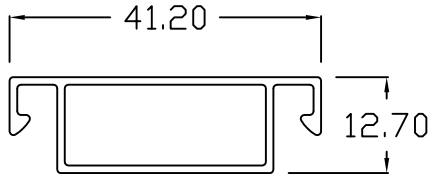

SF - 105
SCREEN CROSSBAR

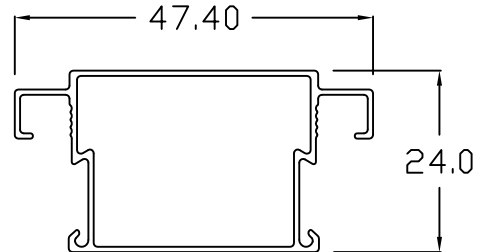

SF - 106
SC. DOOR CROSSBAR

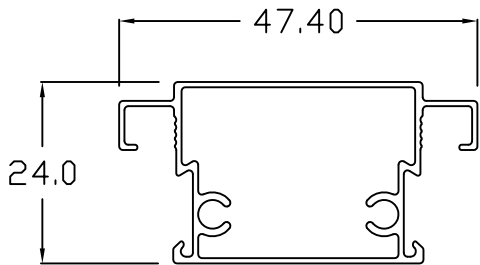

SF - 106 B
CROSSBAR W/ SCREWHOLE

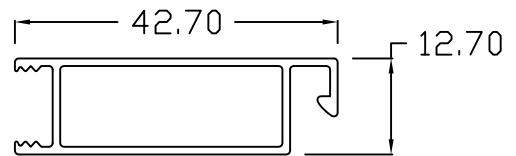

YS - 221
SCREEN FRAME

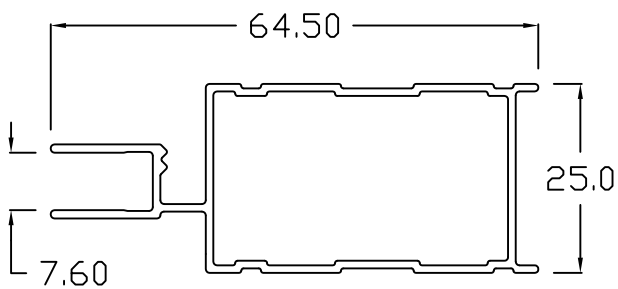

SF - 301
AMPLIMESH SINGLE

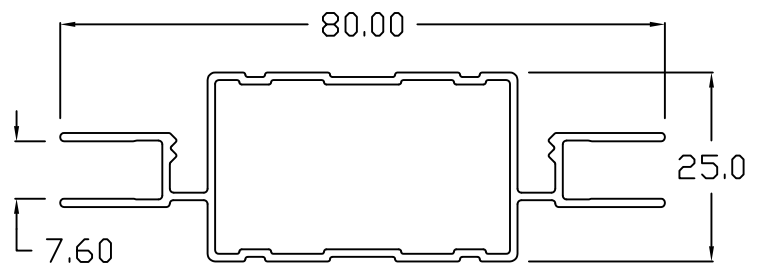

SF - 302
AMPLIMESH DOUBLE



SWING DOOR SECTIONS

TELS.No.7586 - 8309 ,
8990 - 7364
CP.No. 09171838309
FAX.No. 8983 - 2732

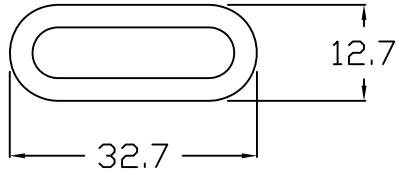

**ED - 101PB
PUSH BAR W/ HOLE**

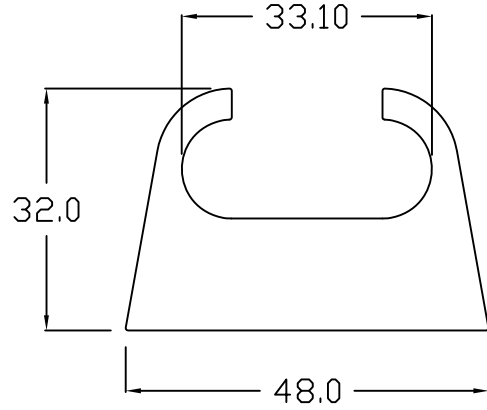

**ED - 101BB
PUSH BAR BRACKET**

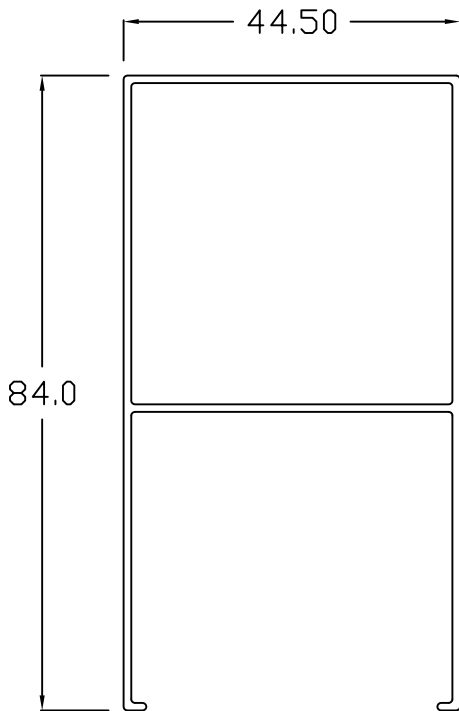

**ED - 101
BOTTOM RAIL**

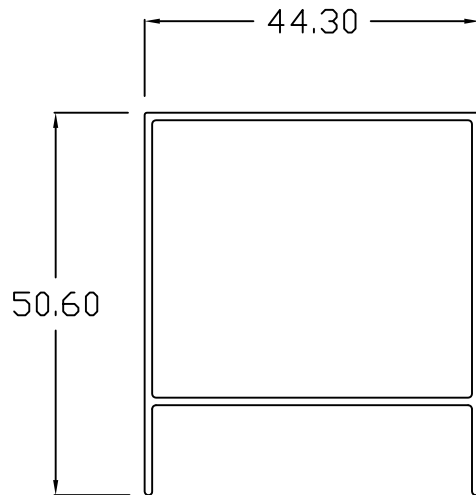

**ED - 102
TOP RAIL**



SWING DOOR SECTIONS

TELS.No.7586 - 8309 ,
8990 - 7364
CP.No. 09171838309
FAX.No. 8983 - 2732

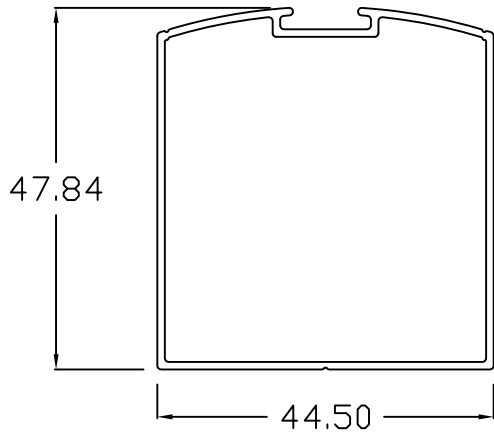

ED - 103
STILE W/ GROOVE

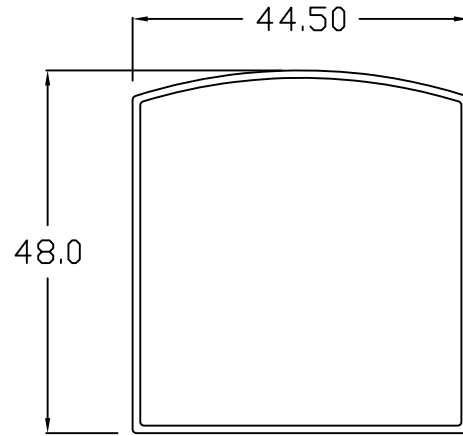

ED - 103A
BULLNOSE STILE

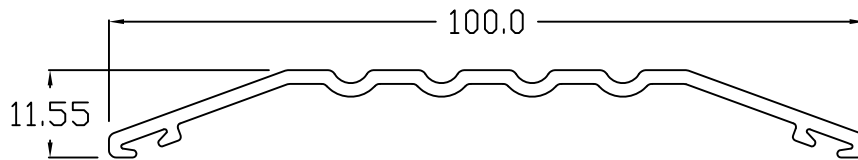

ED - 104
THRESHOLD 4"



SWING DOOR SECTIONS

TELS.No.7586 - 8309 ,
8990 - 7364
CP.No. 09171838309
FAX.No. 8983 - 2732

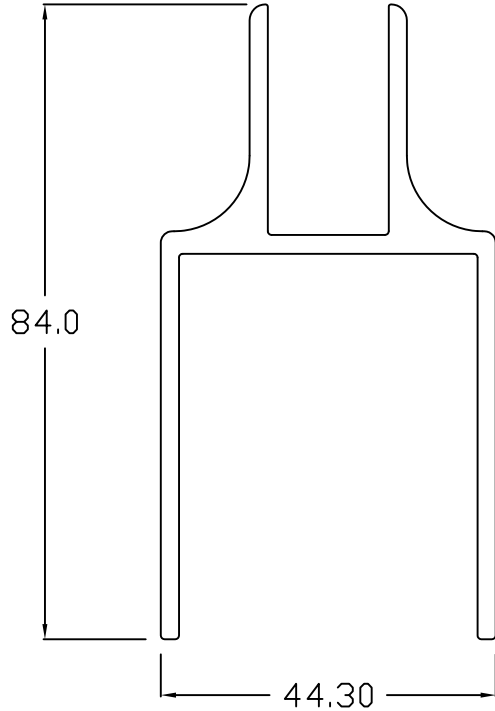

FD 100
FRAMELESS DOOR

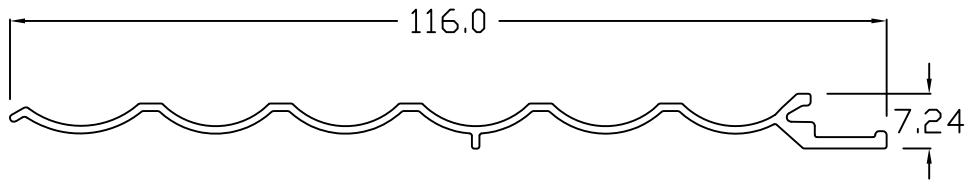

YP 100
BUS BODY SKIN



SWING DOOR SECTIONS

TELS.No.7586 - 8309 ,
8990 - 7364
CP.No. 09171838309
FAX.No. 8983 - 2732

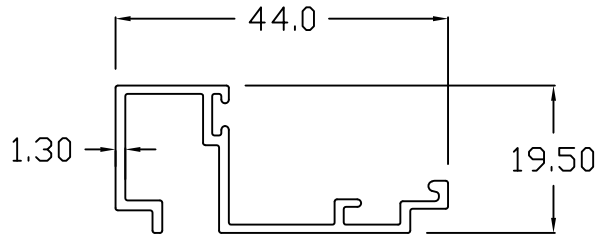

SNAP ON BASE 1/2

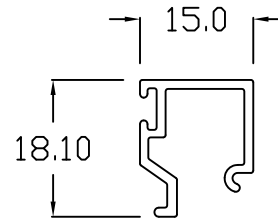

COVER 1/2

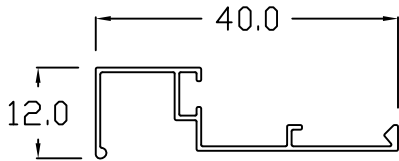

**EF-114
SNAP ON BASE**

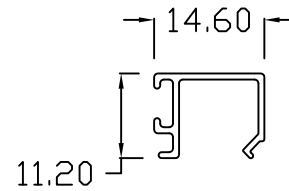

**EF-114A
SNAP ON COVER**



MULLION SECTIONS

TELS.No.7586 - 8309 ,
8990 - 7364
CP.No. 09171838309
FAX.No. 8983 - 2732

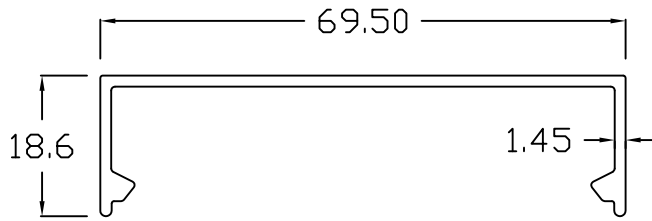

AMAC -C100
COVER Mullion

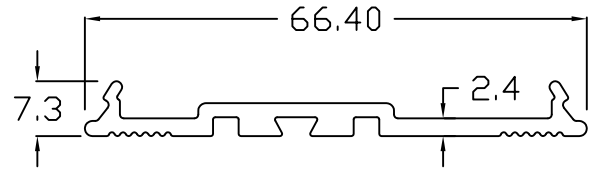

AMAC -A100
ADAPTER Mullion

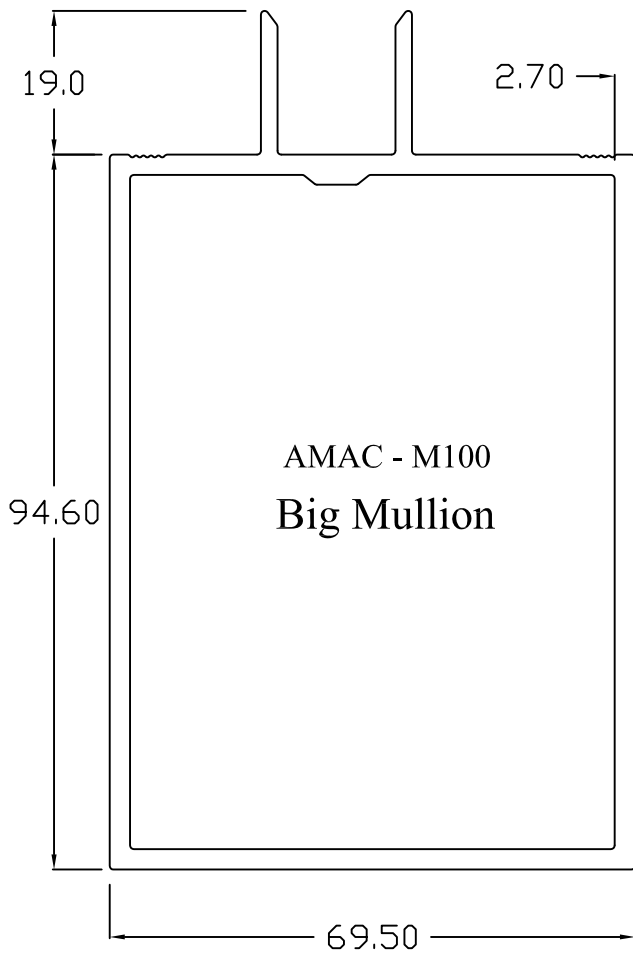

AMAC - M100
Big Mullion

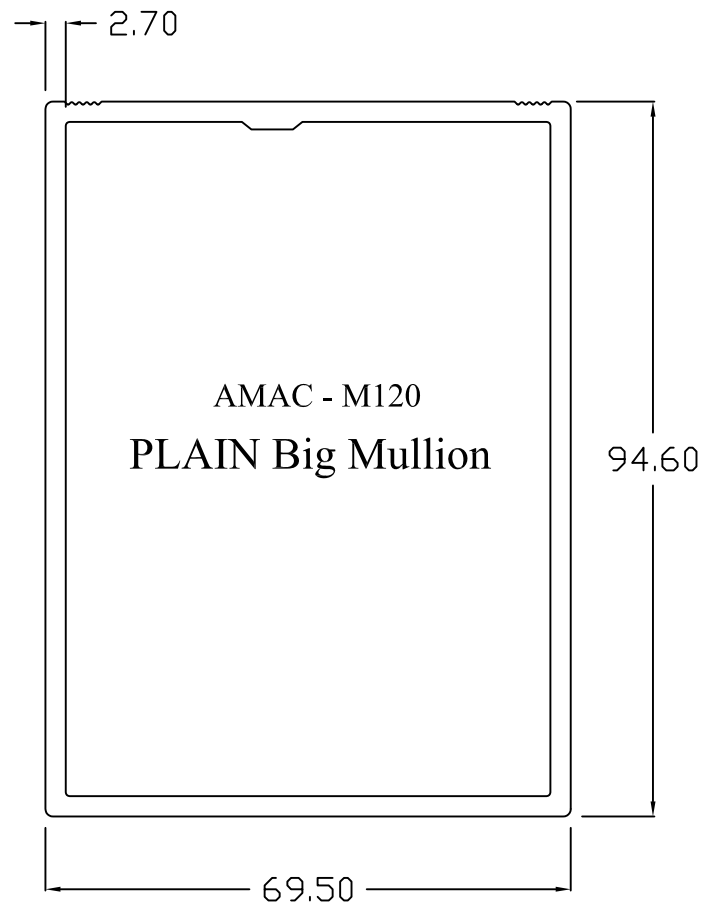

AMAC - M120
PLAIN Big Mullion



MULLION SECTIONS

TELS.No.7586 - 8309 ,
8990 - 7364
CP.No. 09171838309
FAX.No. 8983 - 2732

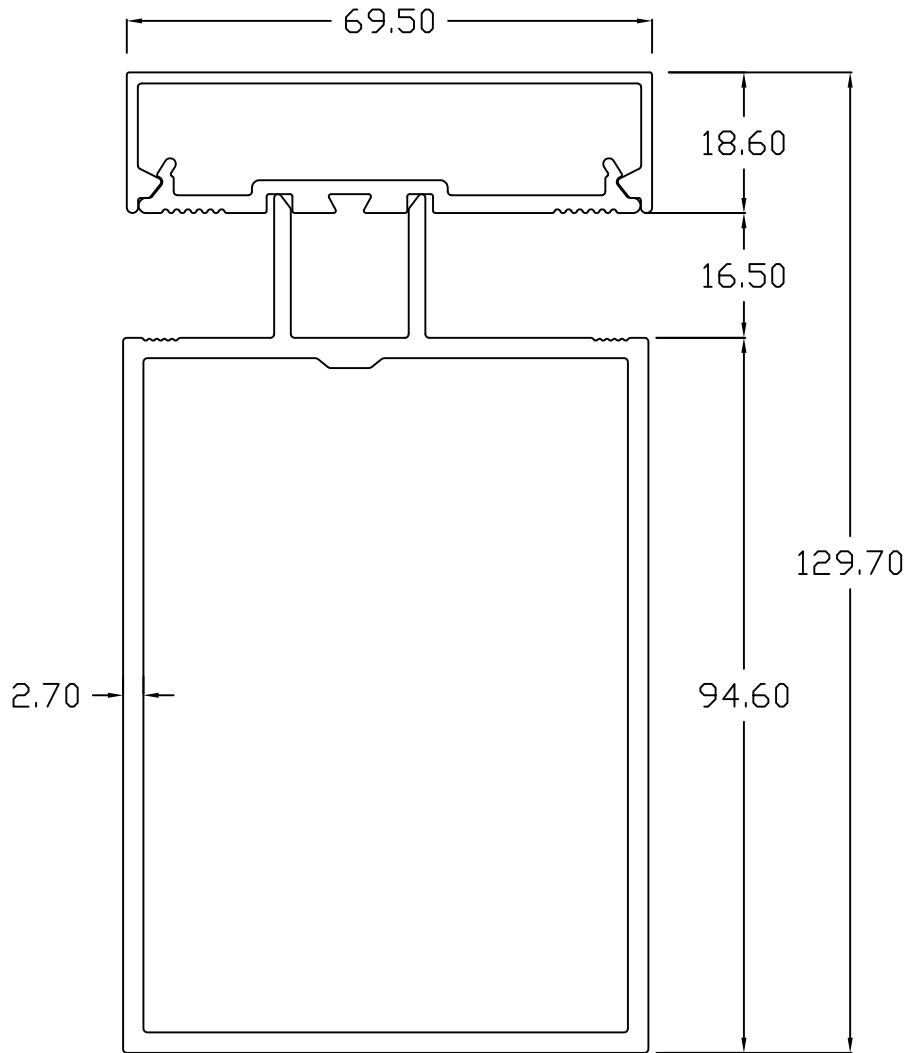

BIG MULLION

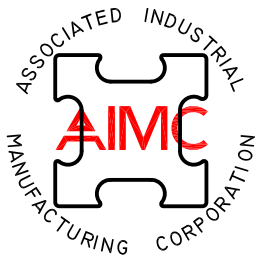

MULLION SECTIONS

TELS.No.7586 - 8309 ,
8990 - 7364
CP.No. 09171838309
FAX.No. 8983 - 2732

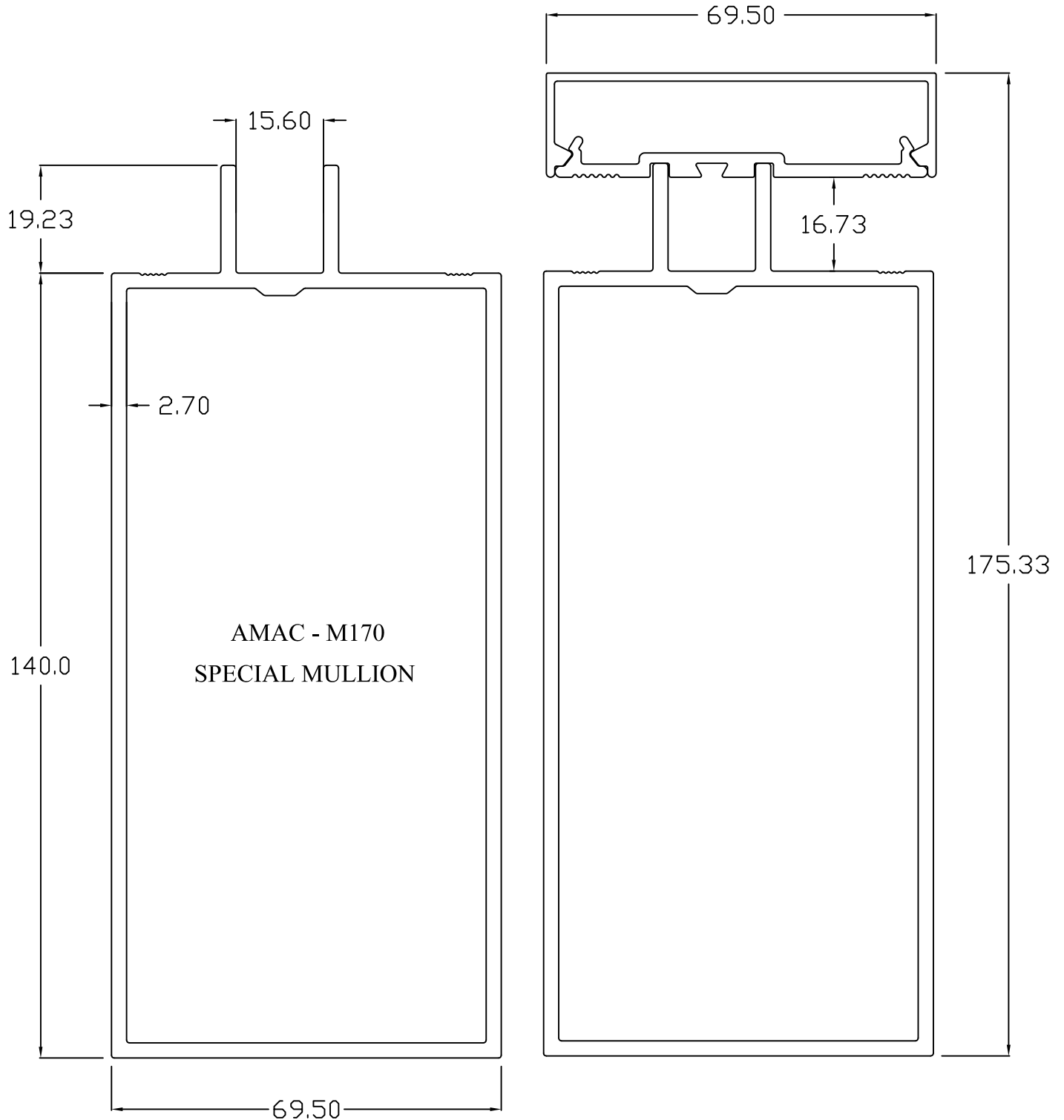



MULLION SECTIONS

TELS.No.7586 - 8309 ,
8990 - 7364
CP.No. 09171838309
FAX.No. 8983 - 2732

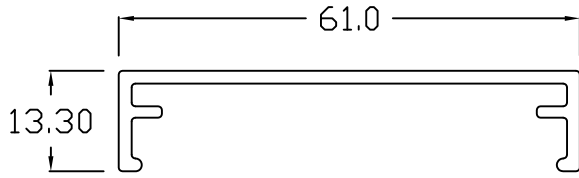

COVER

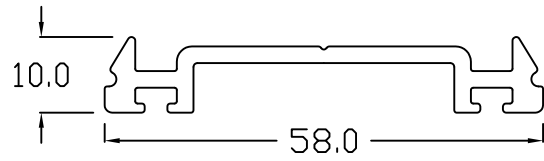

ADAPTER

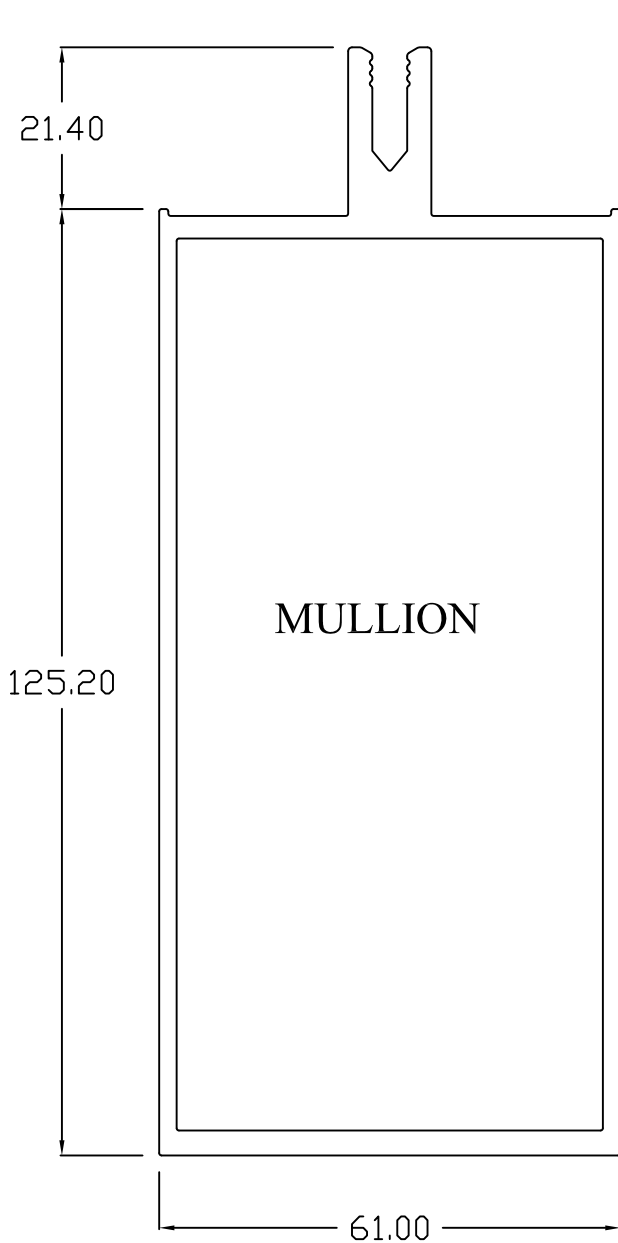

MULLION

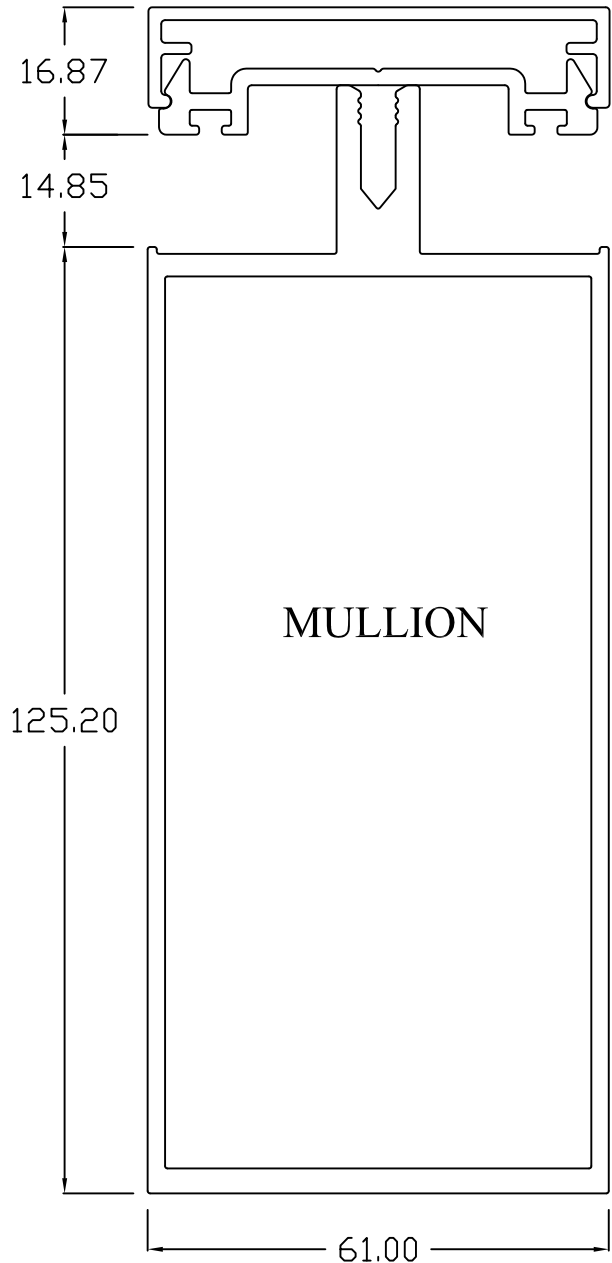

MULLION

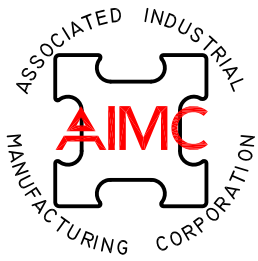

MINI MULLION SECTIONS

TELS.No.7586 - 8309 ,
8990 - 7364
CP.No. 09171838309
FAX.No. 8983 - 2732

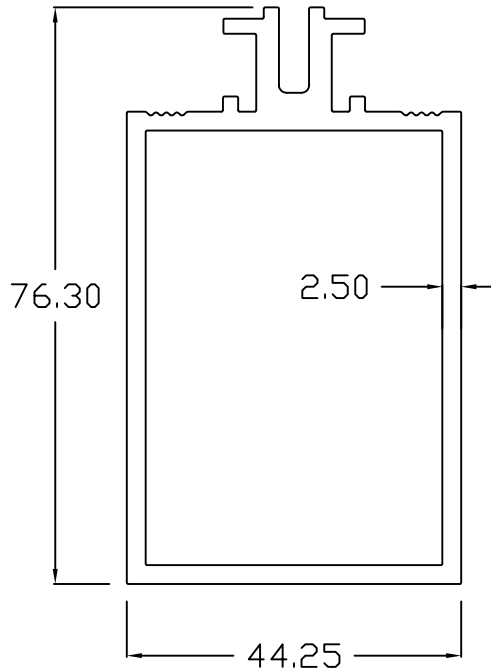

AMAC - M50

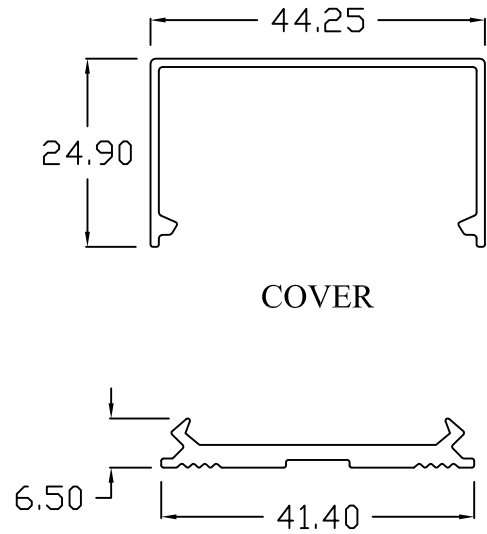

ADAPTER

MINI MULLION WITH PIN

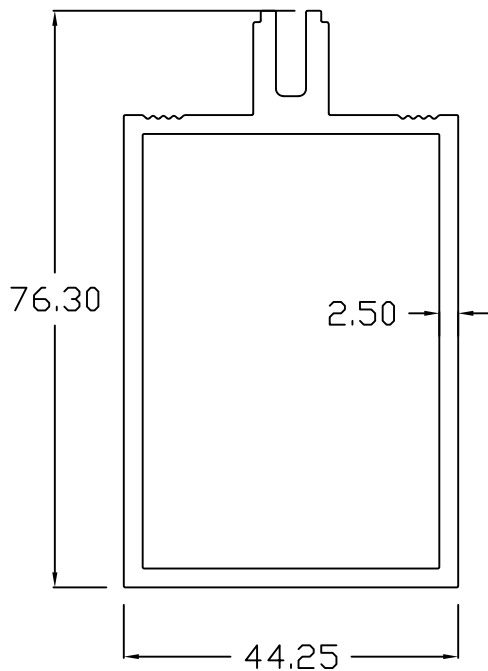

AMAC - M50

MINI MULLION STRAIGHT PIN

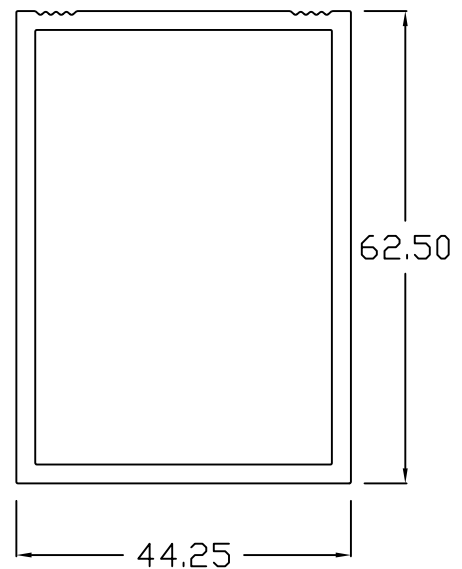

AMAC - M50

PLAIN MINI MULLION



MINI MULLION SECTIONS

TELS.No.7586 - 8309 ,
8990 - 7364
CP.No. 09171838309
FAX.No. 8983 - 2732

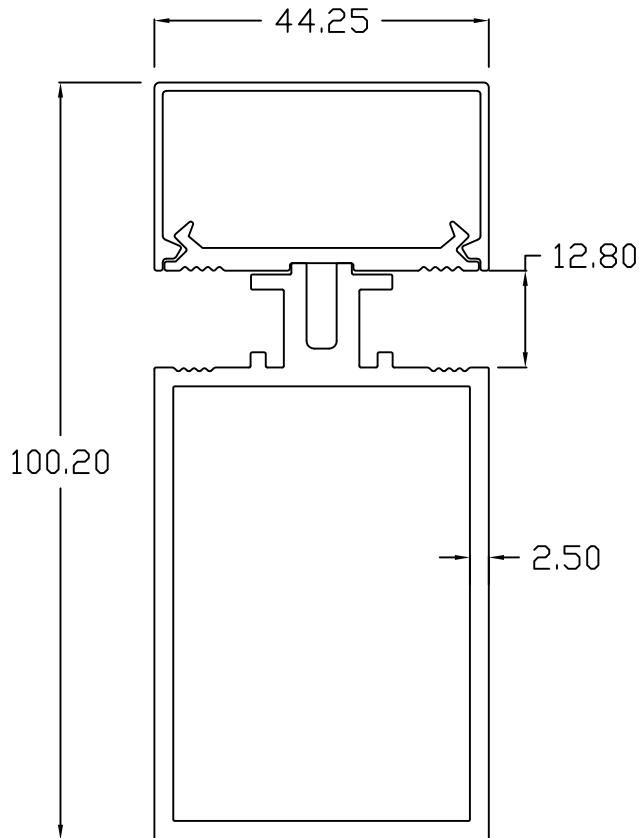

MINI MULLION WITH PIN

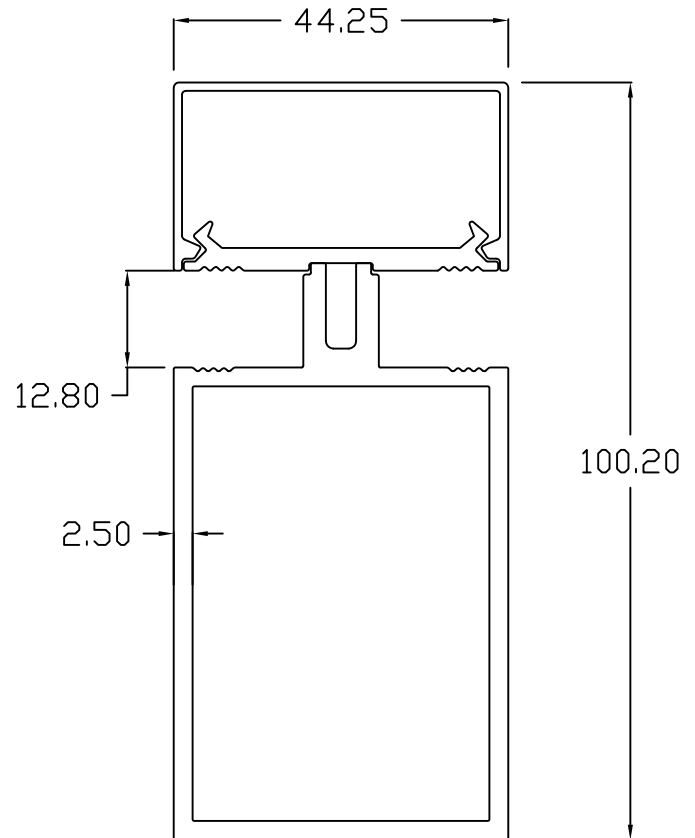

MINI MULLION STRAIGHT PIN



Y - SECTIONS

TELS.No.7586 - 8309 ,
8990 - 7364
CP.No. 09171838309
FAX.No. 8983 - 2732

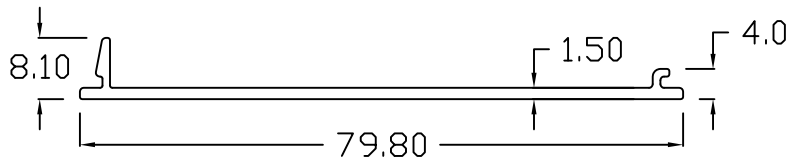

Y 1

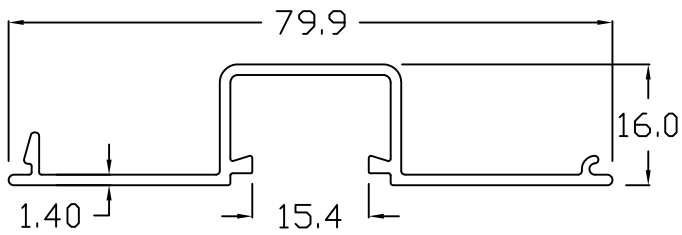

Y 2

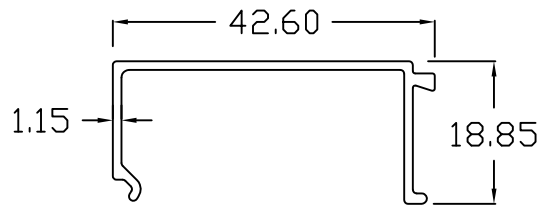

Y 3

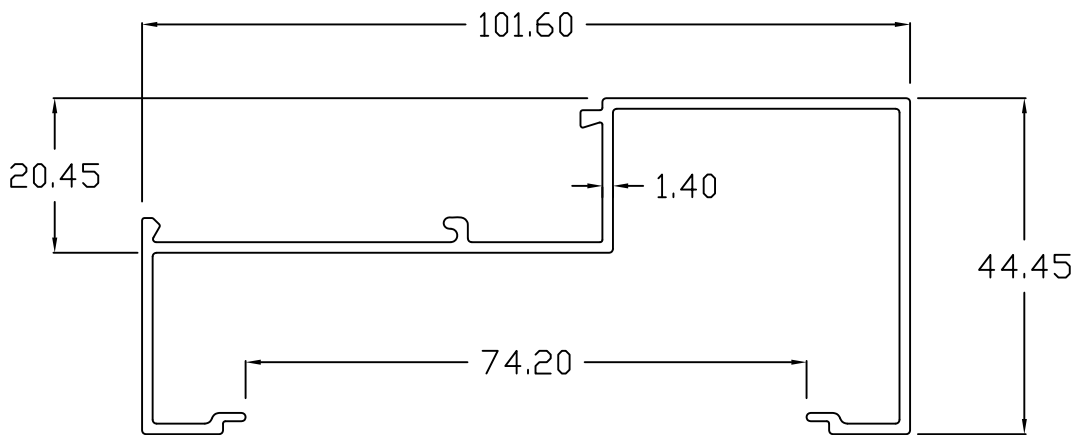

Y 5

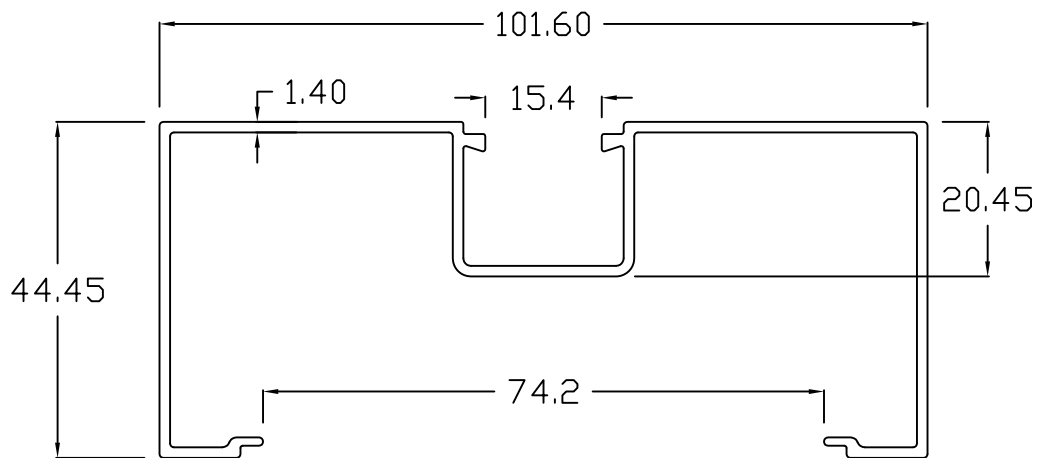

Y 7

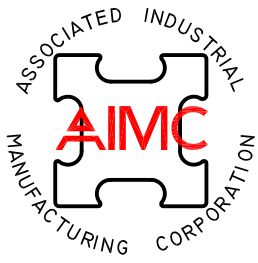

Y - SECTIONS

TELS.No.7586 - 8309 ,
8990 - 7364
CP.No. 09171838309
FAX.No. 8983 - 2732

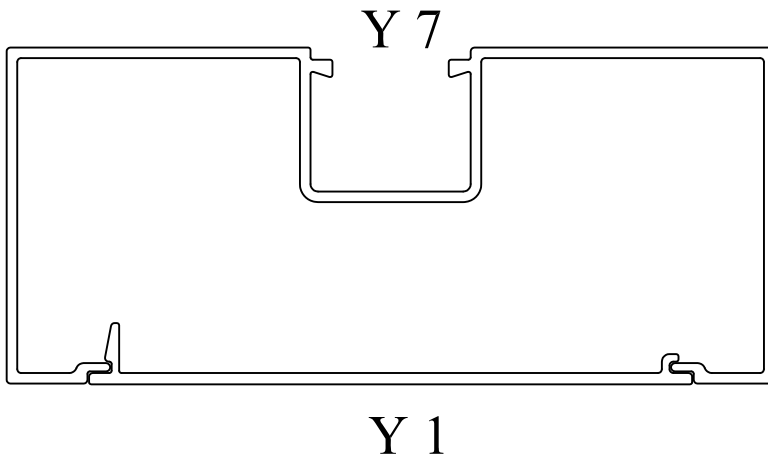
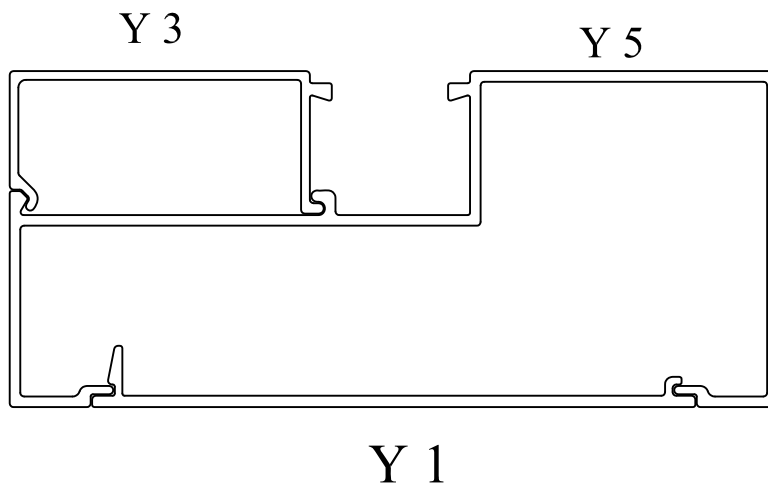
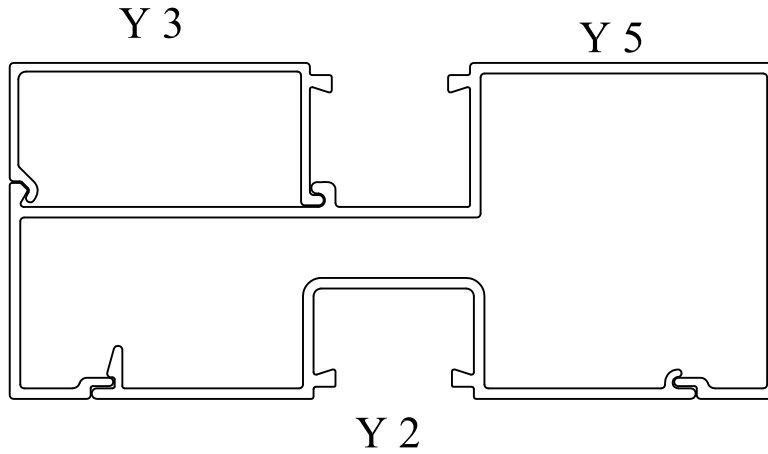

GUIDE FOR Y - SECTION



VENTILATION SECTIONS

TELS.No.7586 - 8309 ,
8990 - 7364
CP.No. 09171838309
FAX.No. 8983 - 2732

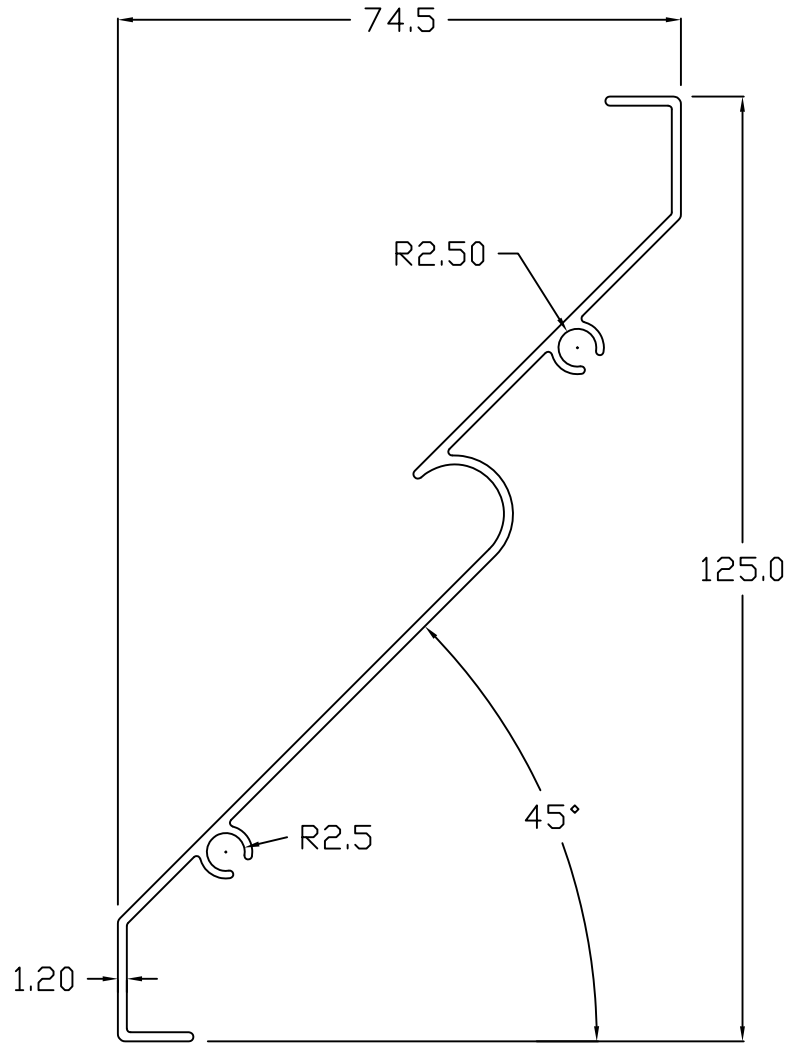

WVA - 42

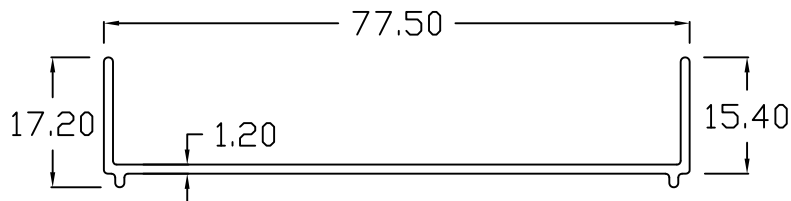

WVA - 43

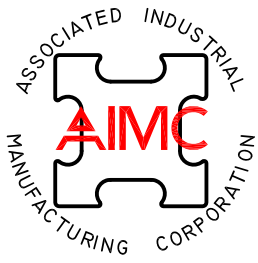

VENTILATION SECTIONS

TELS.No.7586 - 8309 ,
8990 - 7364
CP.No. 09171838309
FAX.No. 8983 - 2732

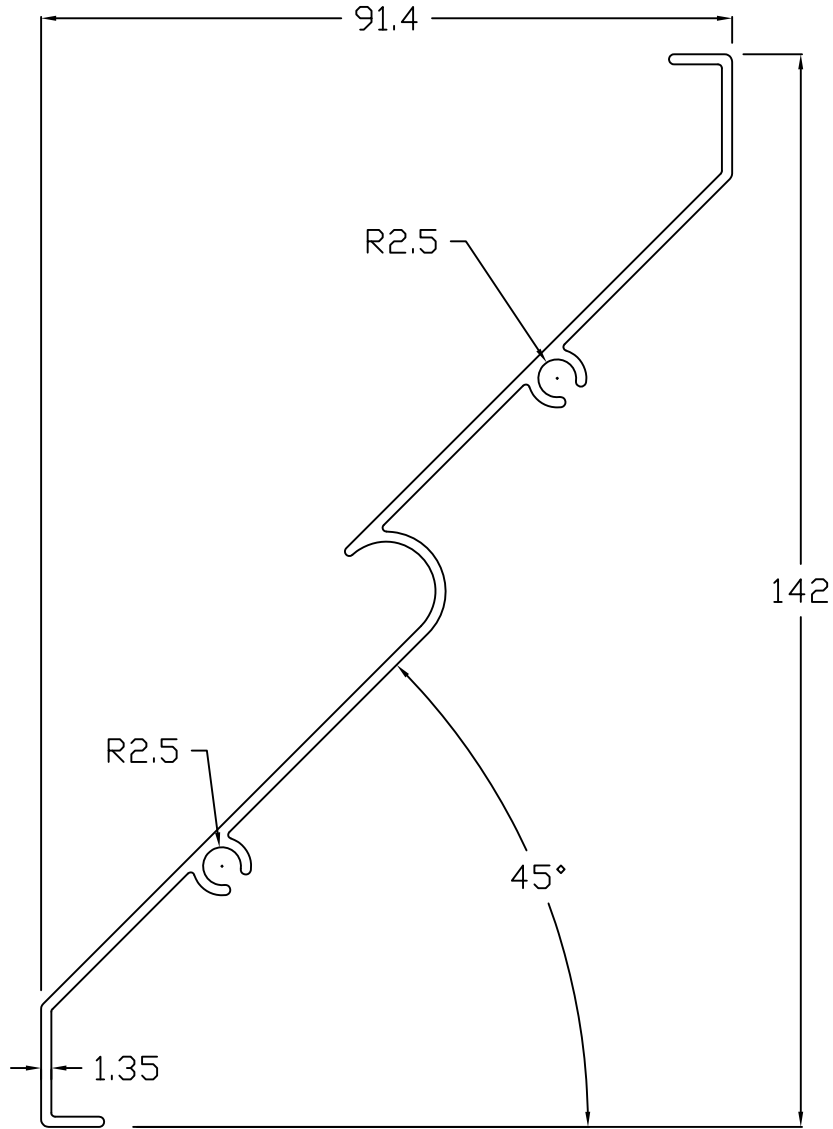

HVA S11

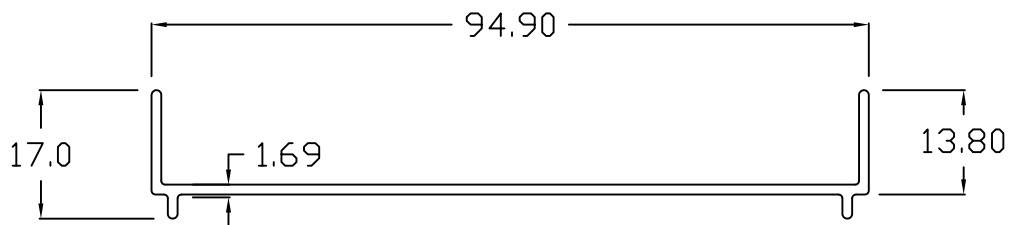

HVA S12

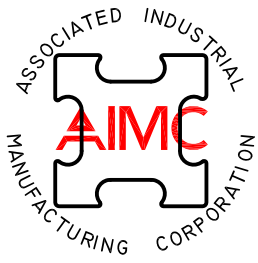

VENTILATION SECTIONS

TELS.No.7586 - 8309 ,
8990 - 7364
CP.No. 09171838309
FAX.No. 8983 - 2732

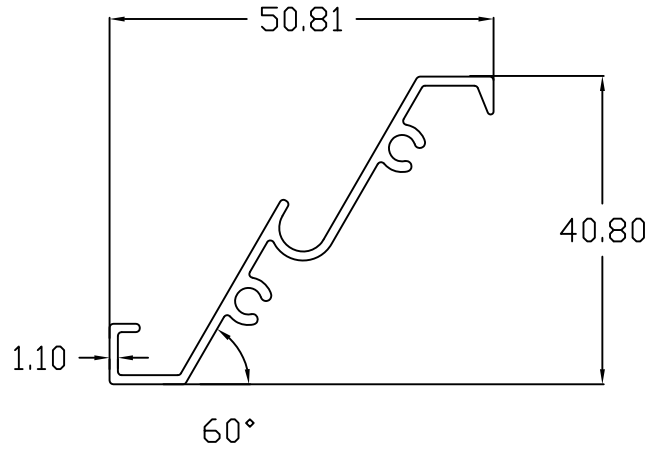

HVA 252

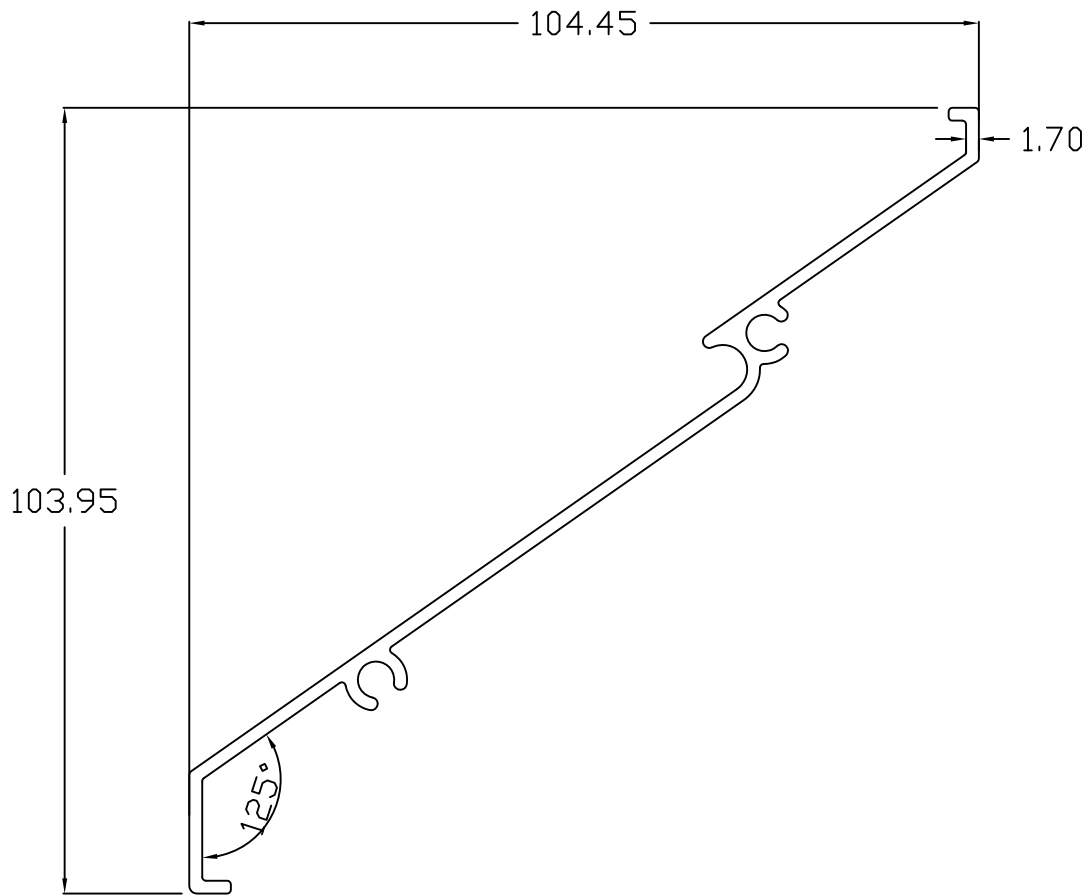

HVA 019

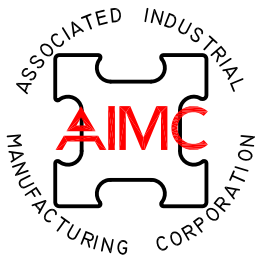

VENTILATION SECTIONS

TELS.No.7586 - 8309 ,
8990 - 7364
CP.No. 09171838309
FAX.No. 8983 - 2732

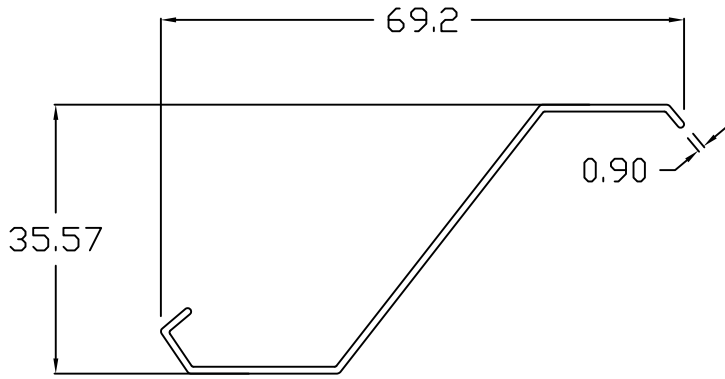

HVA - 222

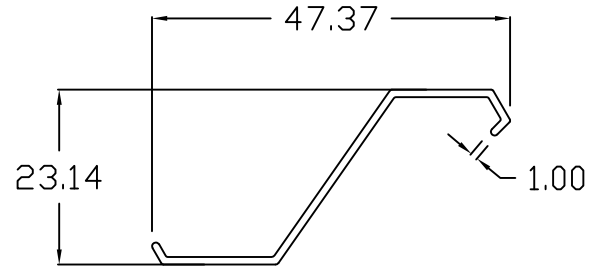

MINI LOUVER

HVA - 325

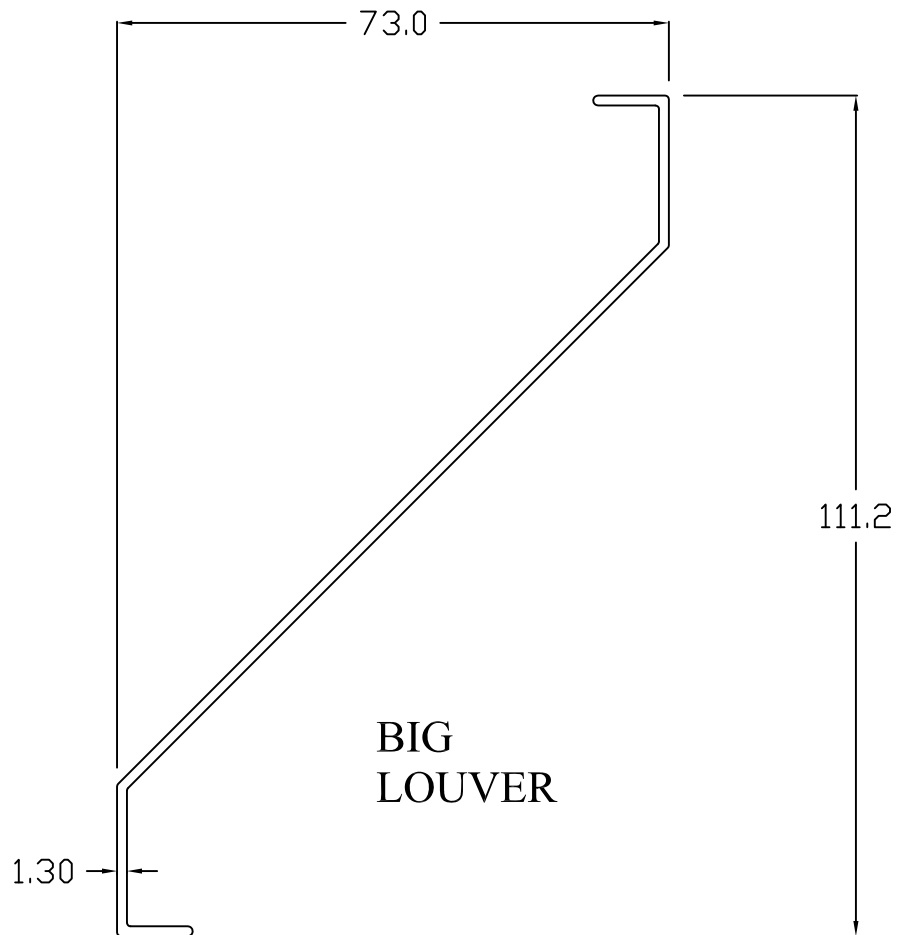

BIG LOUVER



VENTILATION SECTIONS

TELS.No.7586 - 8309 ,
8990 - 7364
CP.No. 09171838309
FAX.No. 8983 - 2732

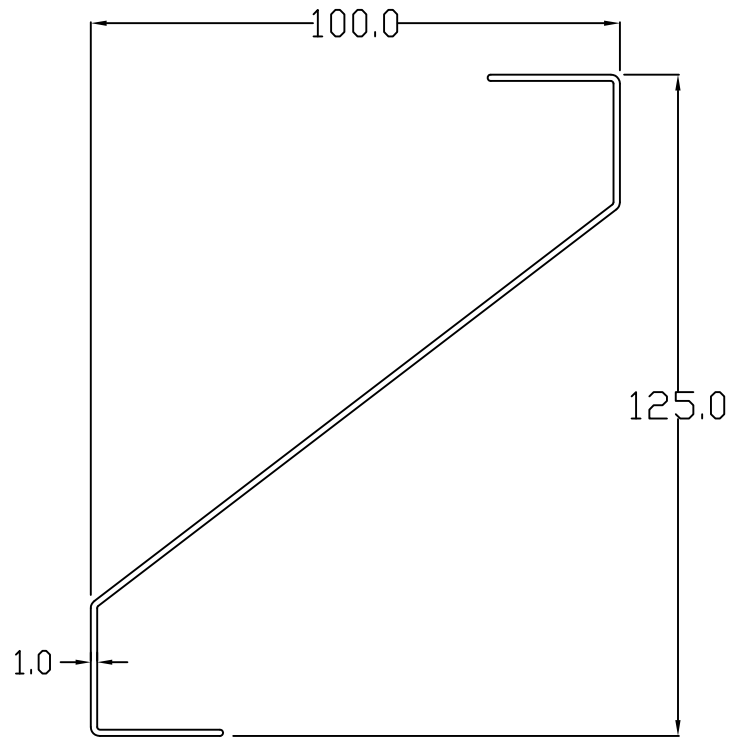

BIG LOUVER 125MM

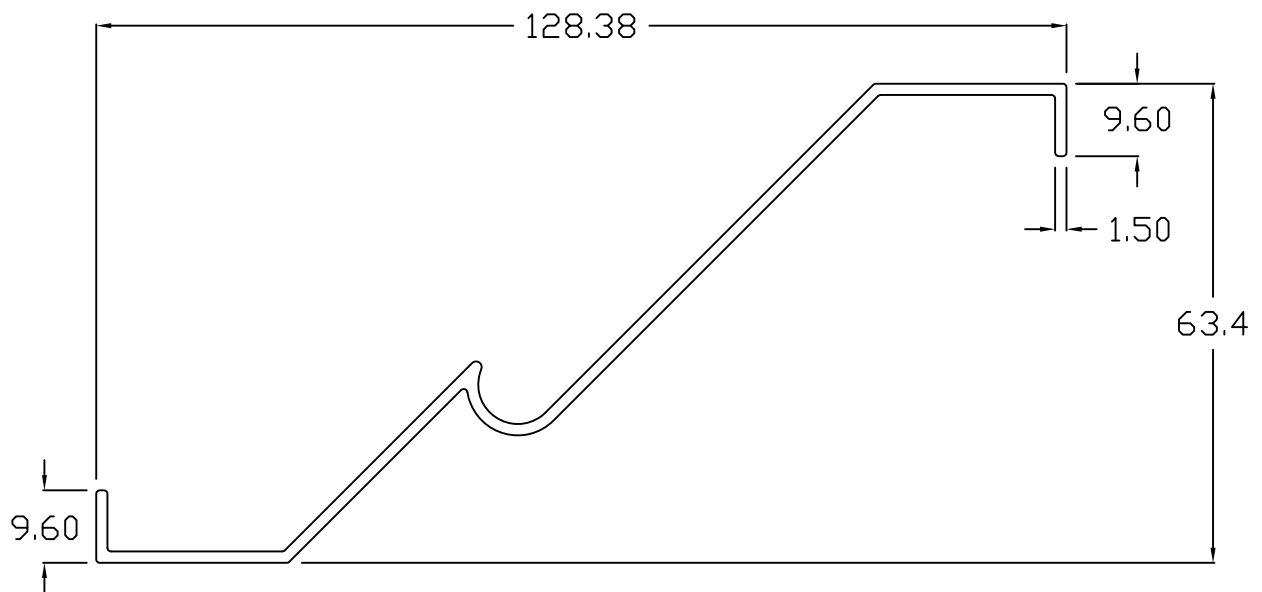

HVA 326



VENTILATION SECTIONS

TELS.No.7586 - 8309 ,
8990 - 7364
CP.No. 09171838309
FAX.No. 8983 - 2732

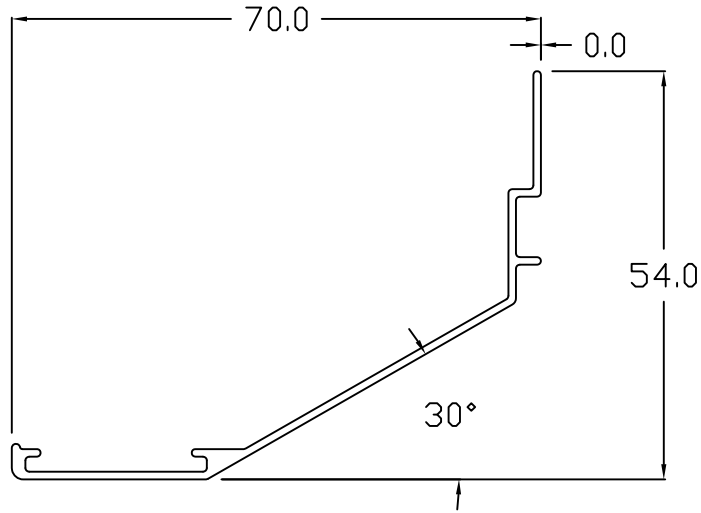

4 WAY DIFFUSER

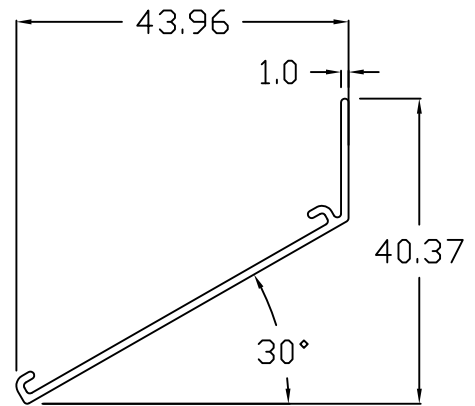
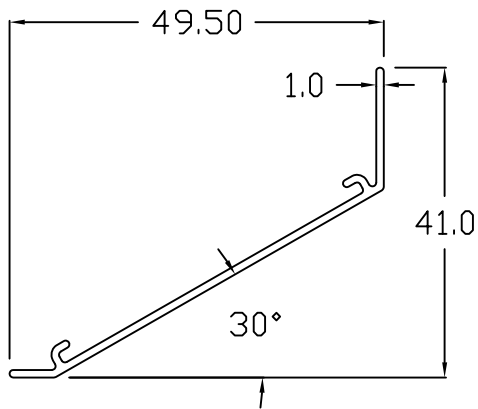



VENTILATION SECTIONS

TELS.No.7586 - 8309 ,
8990 - 7364
CP.No. 09171838309
FAX.No. 8983 - 2732

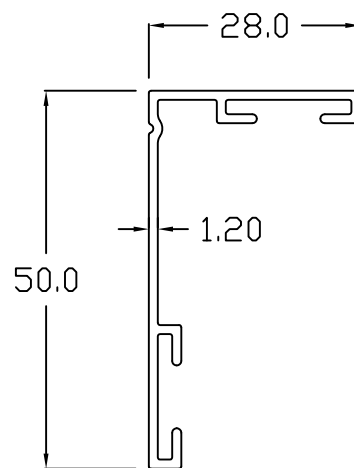
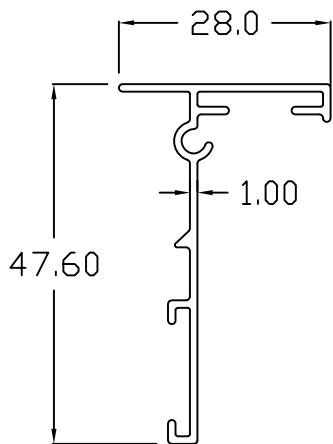
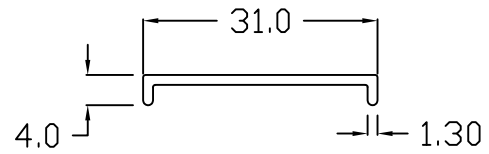
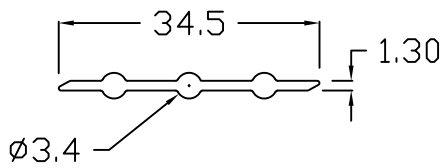
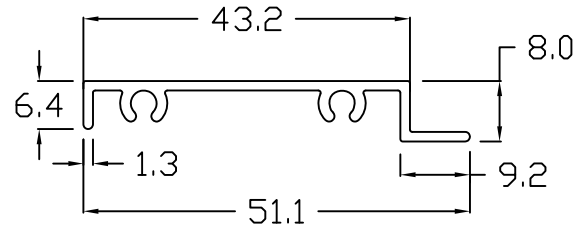
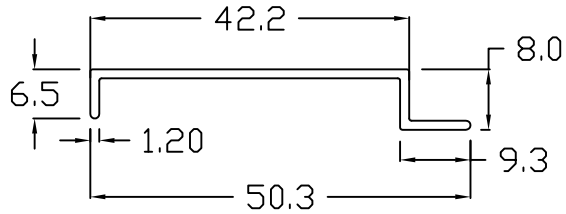

FRAME

FRAME



VENTILATION SECTIONS

TELS.No.7586 - 8309 ,
8990 - 7364
CP.No. 09171838309
FAX.No. 8983 - 2732

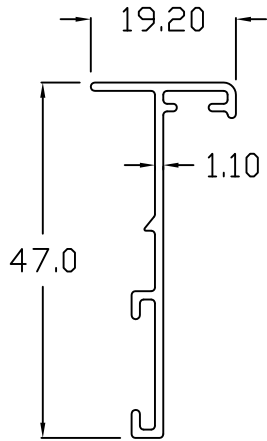

FRAME

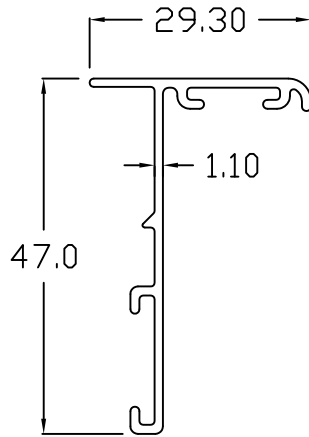

SLOT FRAME

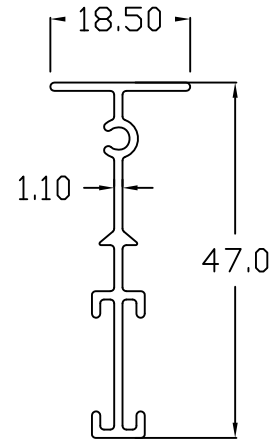

SLOT CENTER FRAME

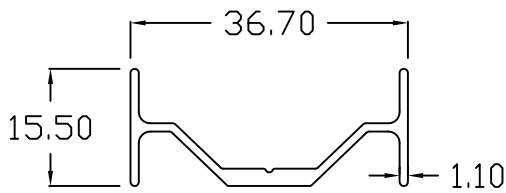

SLOT BRACKET

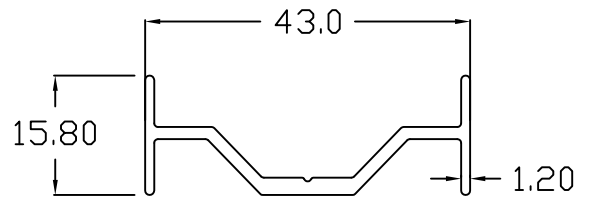

SLOT BRACKET

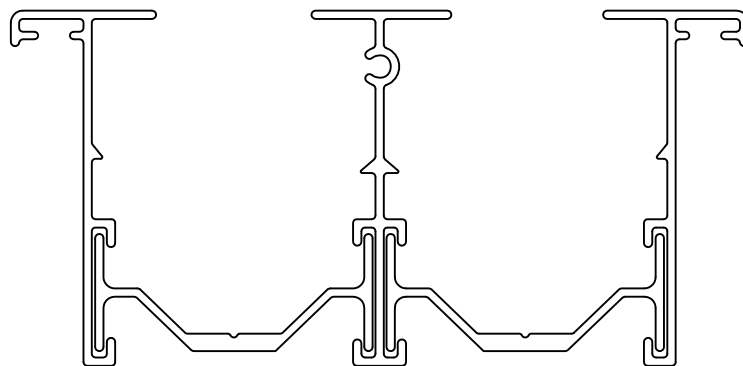



VENTILATION SECTIONS

TELS.No.7586 - 8309 ,
8990 - 7364
CP.No. 09171838309
FAX.No. 8983 - 2732

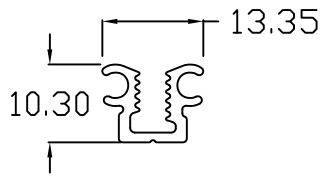

BLADE 1

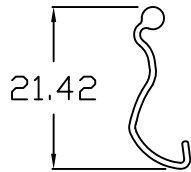

BLADE 2

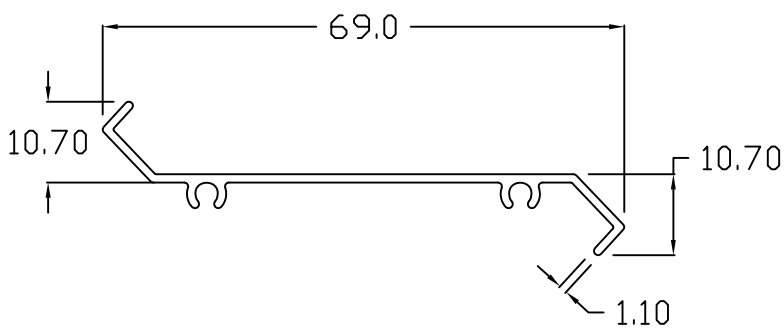
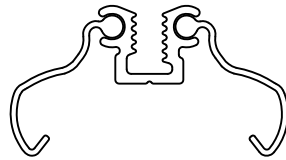
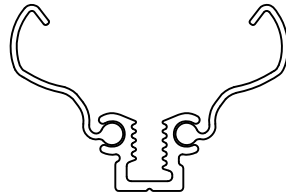

LOUVER

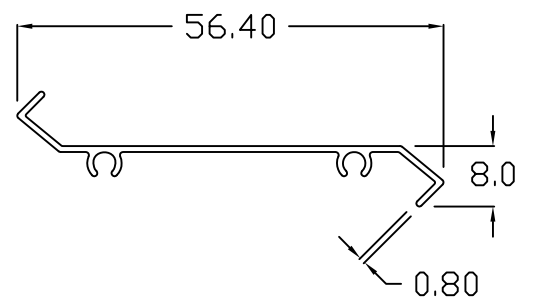

LOUVER



VENTILATION SECTIONS

TELS.No.7586 - 8309 ,
8990 - 7364
CP.No. 09171838309
FAX.No. 8983 - 2732

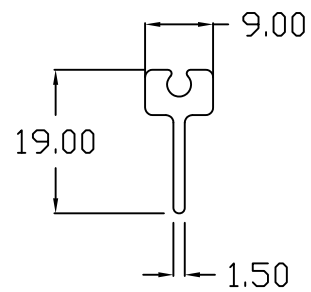
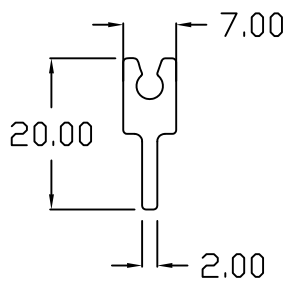
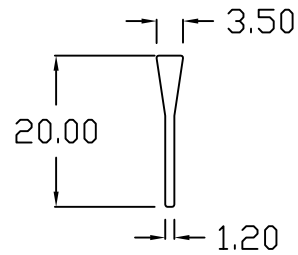
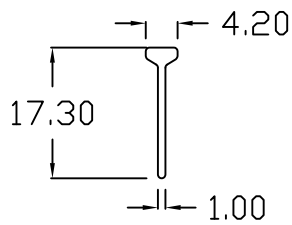
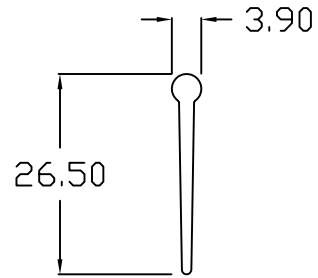
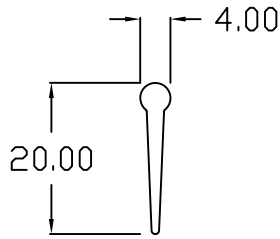



38 SERIES

TELS.No.7586 - 8309 ,
8990 - 7364
CP.No. 09171838309
FAX.No. 8983 - 2732

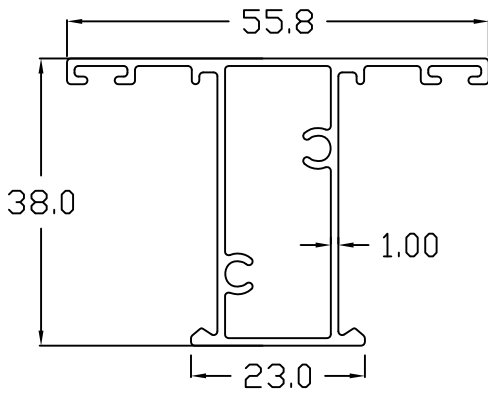

38 - 4 (CENTER)

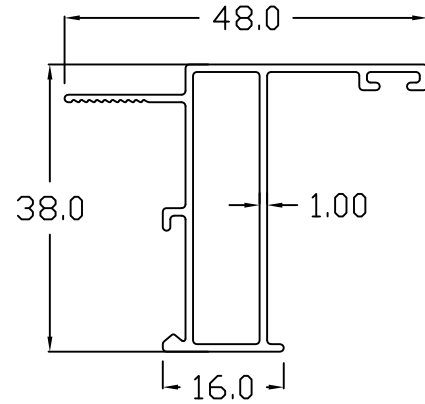

38 - 2 (PANEL)

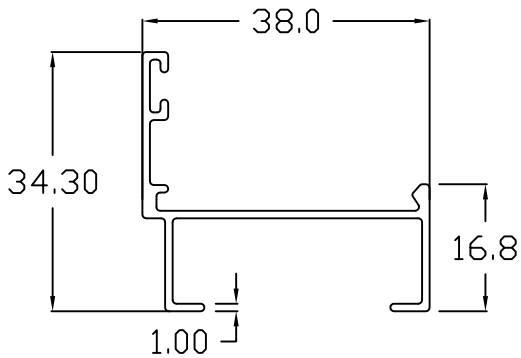

38 - 2A (PERIMETER)

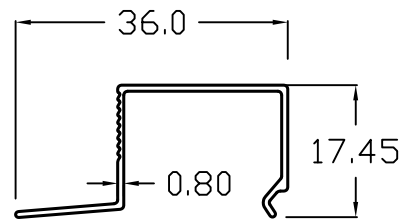

38 - 12
(COVER BIG SQUARE)

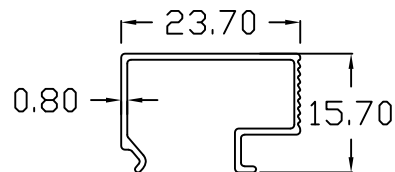

38 - 12
(COVER SMALL SQUARE)



50 SERIES

TELS.No.7586 - 8309 ,
8990 - 7364
CP.No. 09171838309
FAX.No. 8983 - 2732

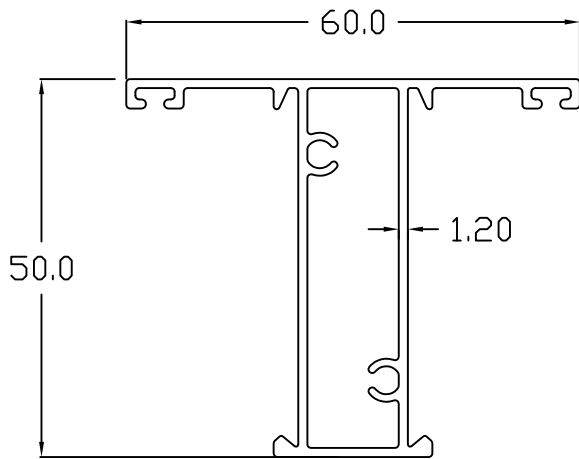

50 - 4

CENTER FRAME W/ HOLE

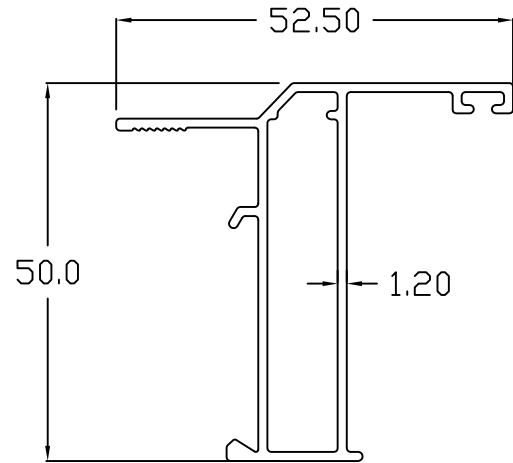

50 - 2

PANEL

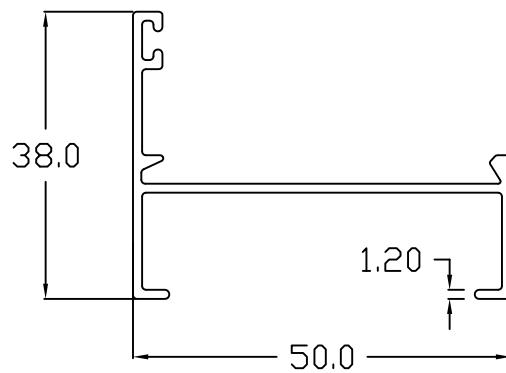

50-2A

PERIMETER



50 SERIES

TELS.No.7586 - 8309 ,
8990 - 7364
CP.No. 09171838309
FAX.No. 8983 - 2732

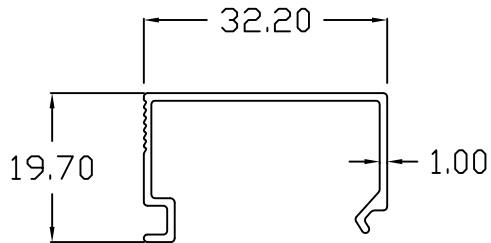

50-12
SMALL SQUARE

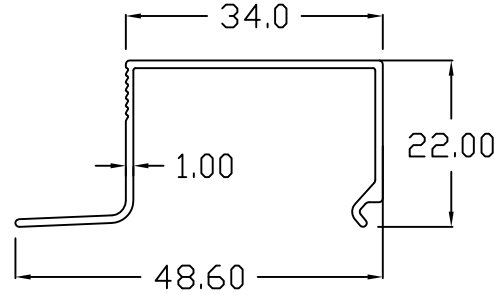

50-12
BIG SQUARE

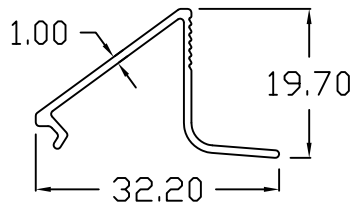

IGU SMALL SLANT

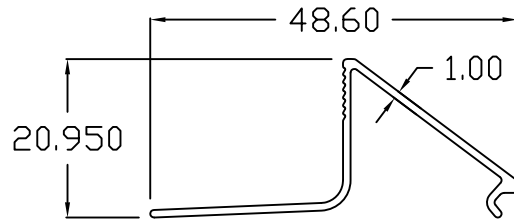

IGU BIG SLANT

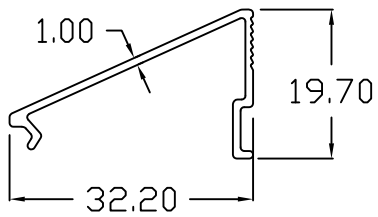

YC - 50 -12 S6
SMALL SLANT

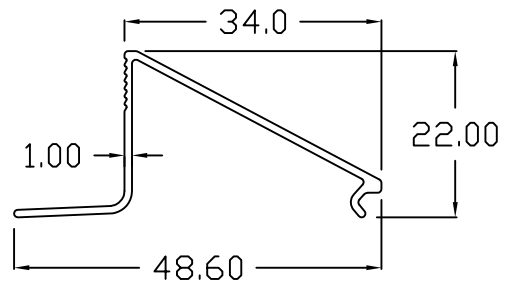

BIG SLANT



798 SERIES

TELS.No.7586 - 8309 ,
8990 - 7364
CP.No. 09171838309
FAX.No. 8983 - 2732

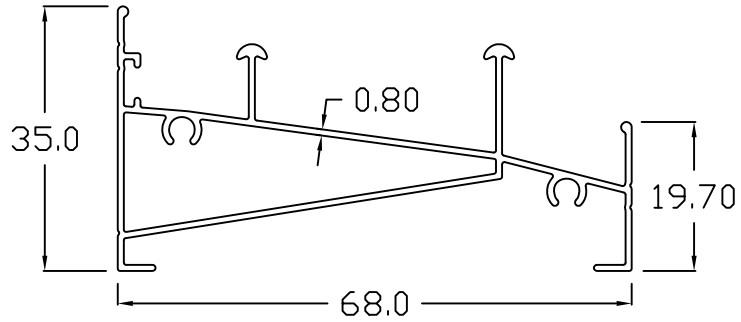

DOUBLE SILL

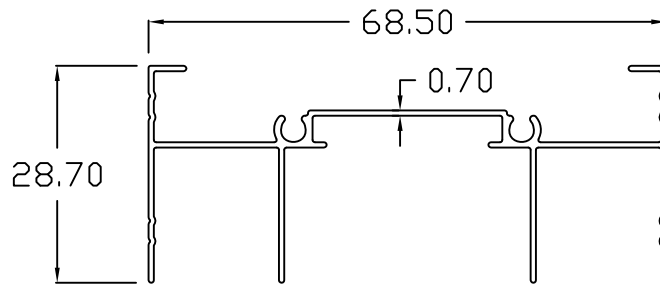

DOUBLE HEAD

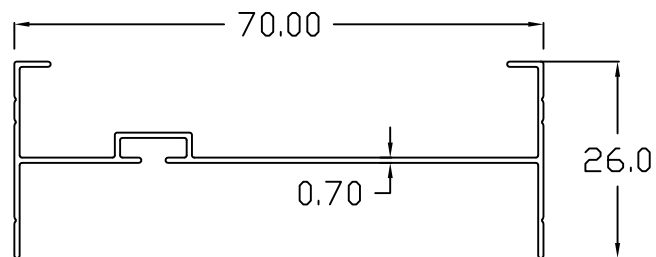

DOUBLE JAMB



798 SERIES

TELS.No.7586 - 8309 ,
8990 - 7364
CP.No. 09171838309
FAX.No. 8983 - 2732

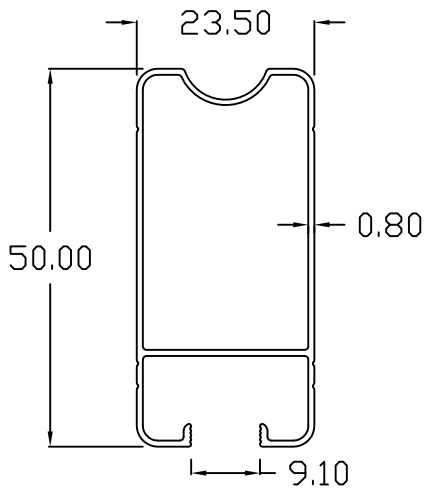

LOCKSTILE

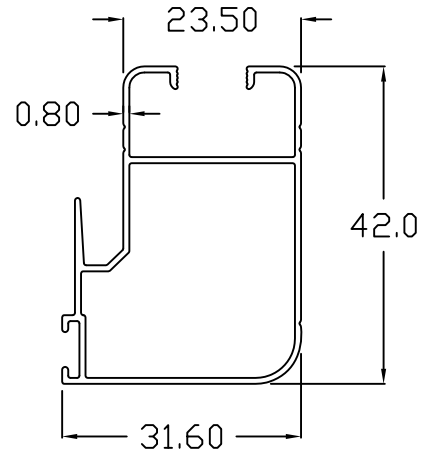

INTERLOCKER

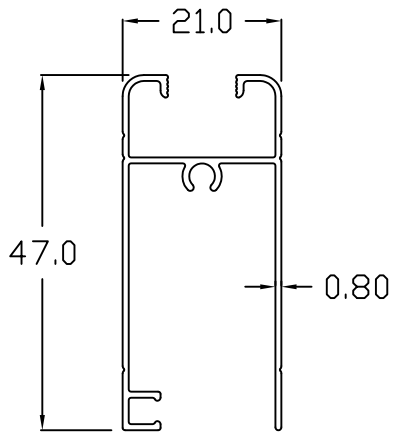

TOP / BOTTOM RAIL

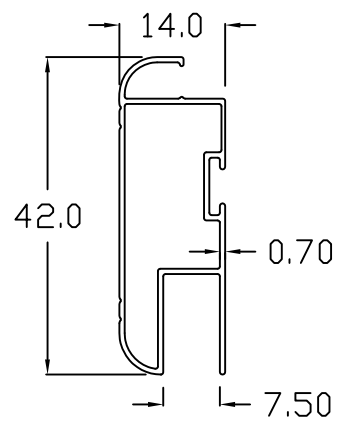

SCREEN FRAME



BFPI SECTIONS

TELS.No.7586 - 8309 ,
8990 - 7364
CP.No. 09171838309
FAX.No. 8983 - 2732

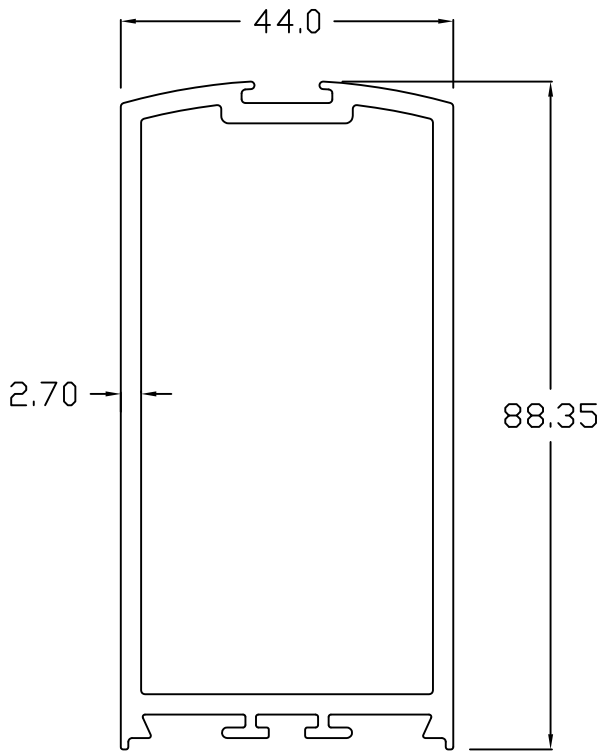

BFPI - 001

STILE WITH GROOVE - 001

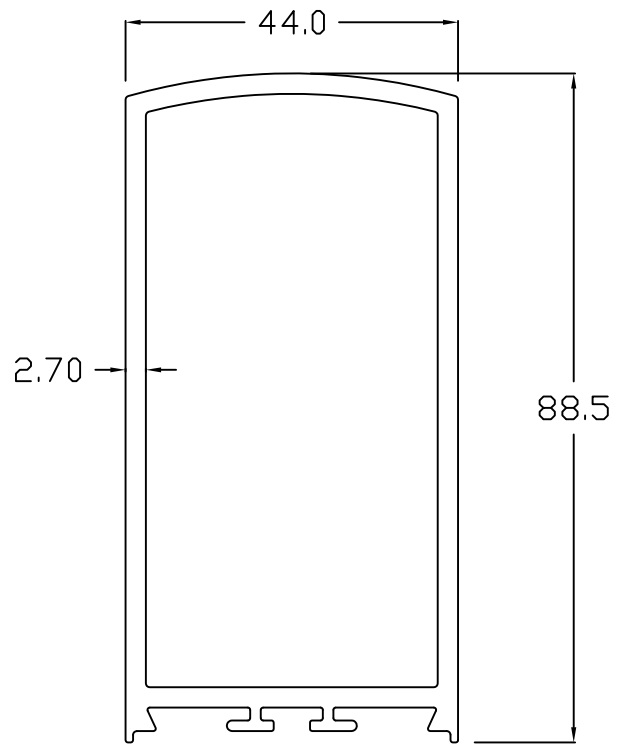

BFPI - 002

BULLNOSE STILE - 002



BFPI SECTIONS

TELS.No.7586 - 8309 ,
8990 - 7364
CP.No. 09171838309
FAX.No. 8983 - 2732

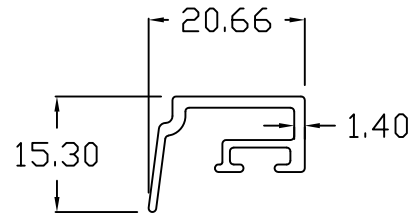
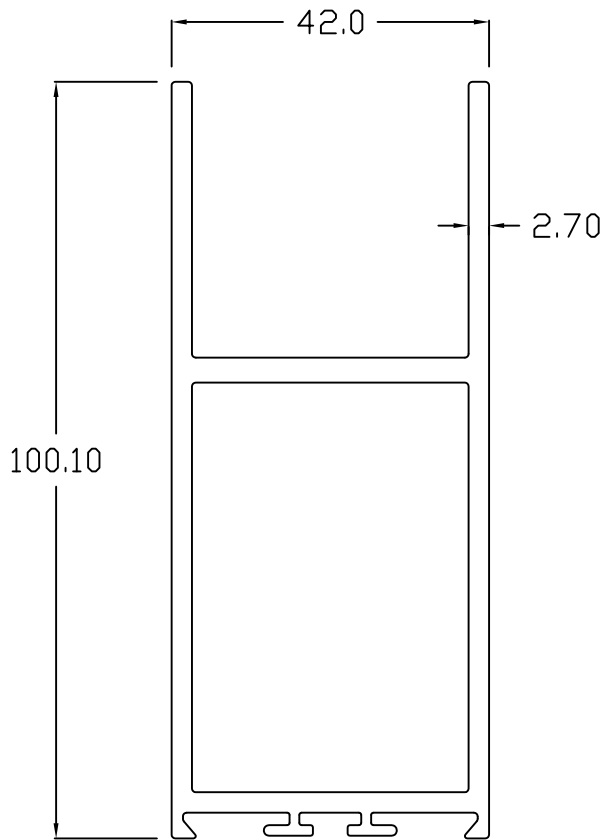

BFPI - 004

COVER

BFPI - 003

TOP / BOTTOM - 003



SENZA SECTIONS

TELS.No.7586 - 8309 ,
8990 - 7364
CP.No. 09171838309
FAX.No. 8983 - 2732

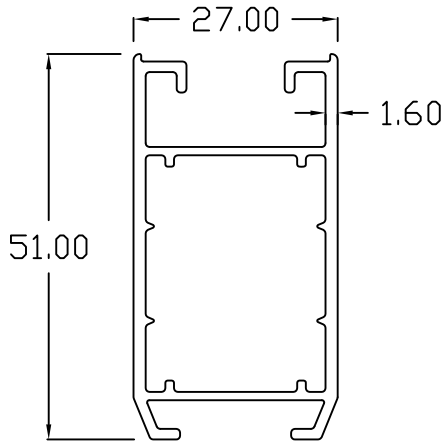

SENZA - 803
LOCKSTILE

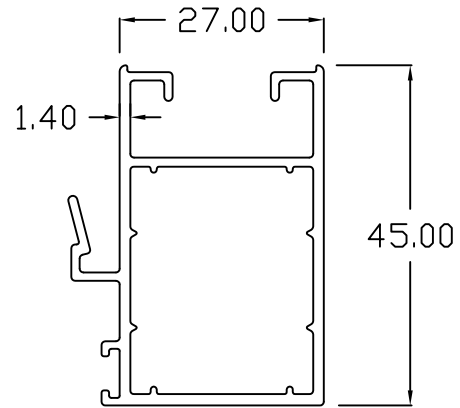

SENZA - 805
INTER LOCKER

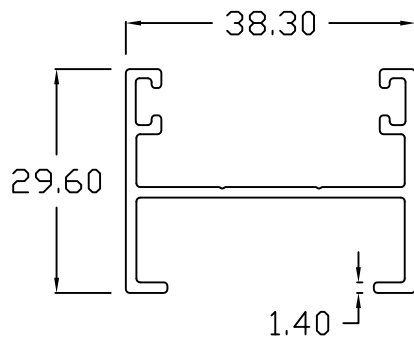

SENZA - 806
ASTRAGAL

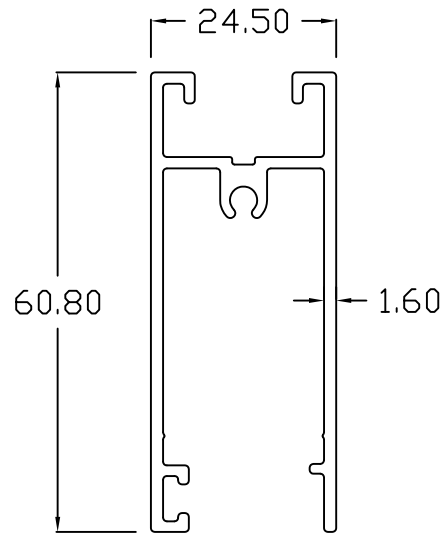

SENZA - 824
BOTTOM RAIL



SENZA SECTIONS

TELS.No.7586 - 8309 ,
8990 - 7364
CP.No. 09171838309
FAX.No. 8983 - 2732

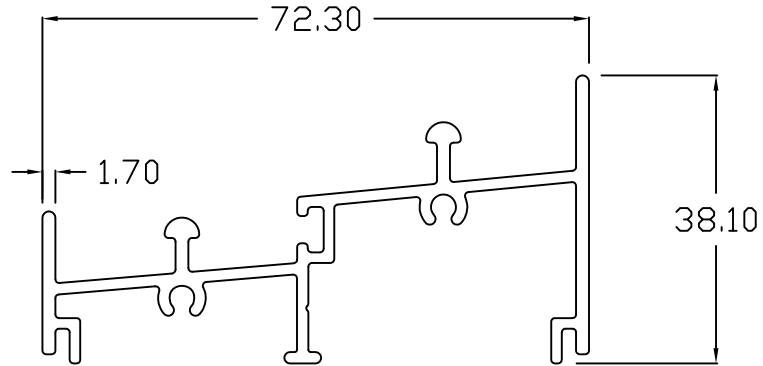

SENZA - 831
DOUBLE SILL

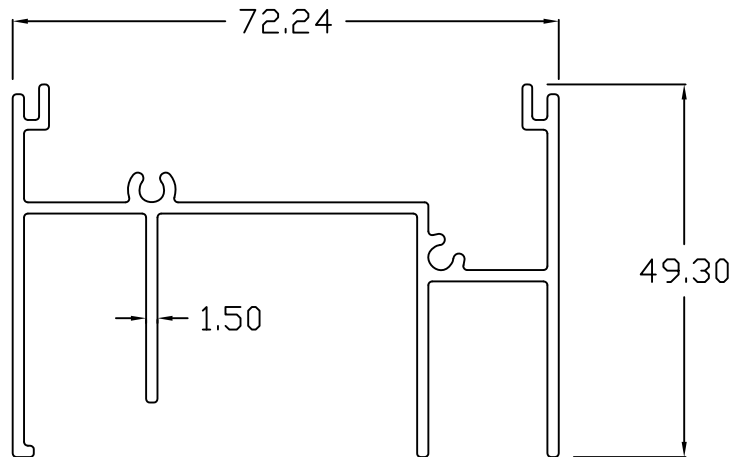

SENZA - 832
DOOR HEAD



SENZA SECTIONS

TELS.No.7586 - 8309 ,
8990 - 7364
CP.No. 09171838309
FAX.No. 8983 - 2732

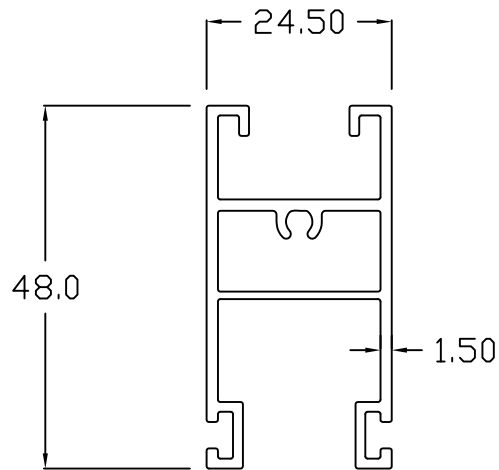

SENZA - 833

TOP RAIL

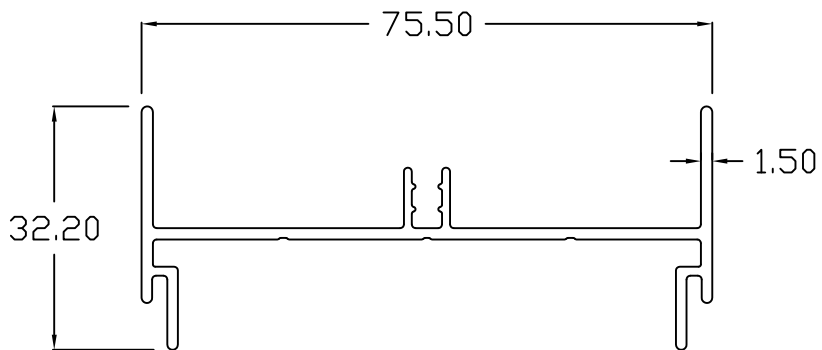

SENZA - 834

DOOR JAMB



900 SERIES

TELS.No.7586 - 8309 ,
8990 - 7364
CP.No. 09171838309
FAX.No. 8983 - 2732

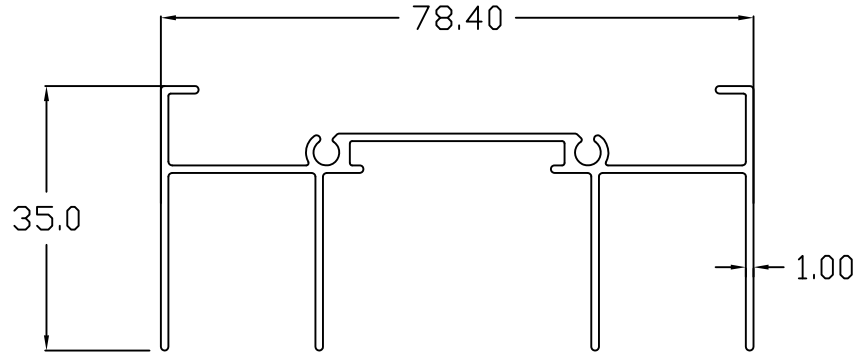

90001
HEADER

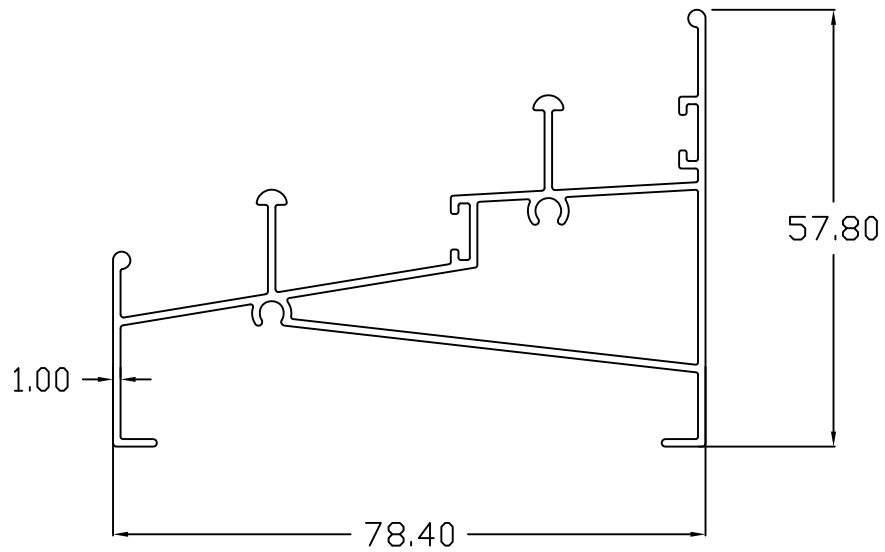

90002
SILL

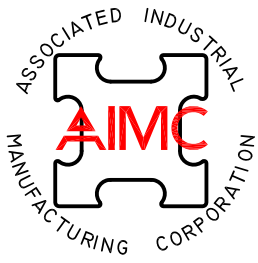

900 SERIES

TELS.No.7586 - 8309 ,
8990 - 7364
CP.No. 09171838309
FAX.No. 8983 - 2732

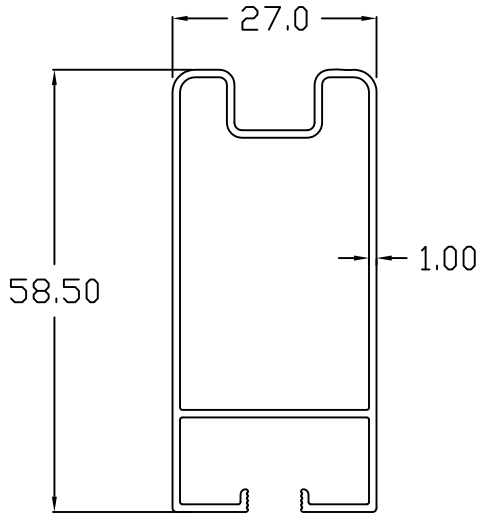

90006
LOCKSTILE

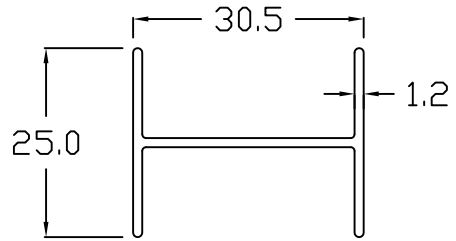

9000
ASTRAGAL

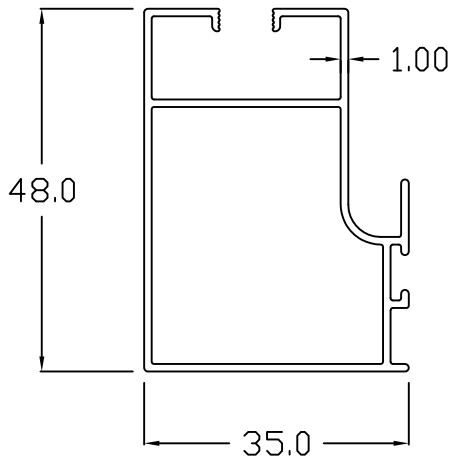

90007
INTERLOCKER

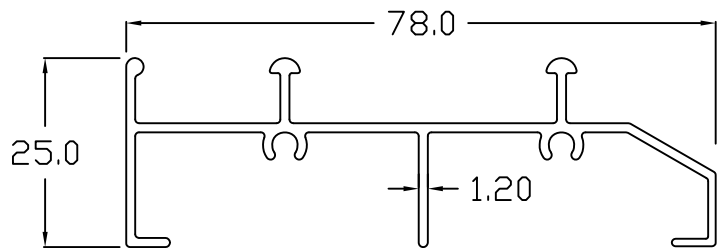

9008
DOUBLE FLAT SILL



900 SERIES

TELS.No.7586 - 8309 ,
8990 - 7364
CP.No. 09171838309
FAX.No. 8983 - 2732

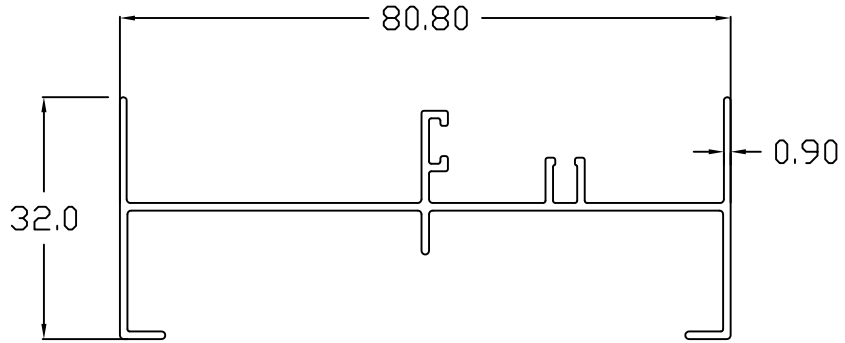

90003
JAMB

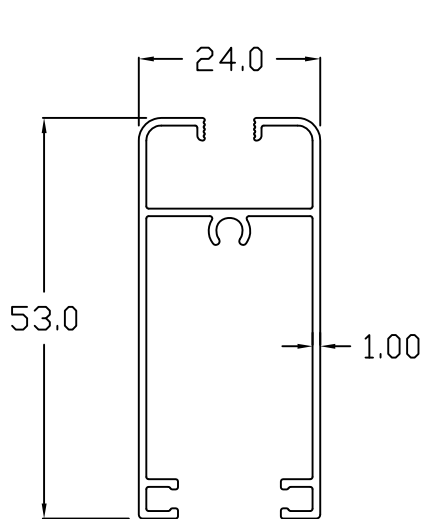

90004
TOP RAIL

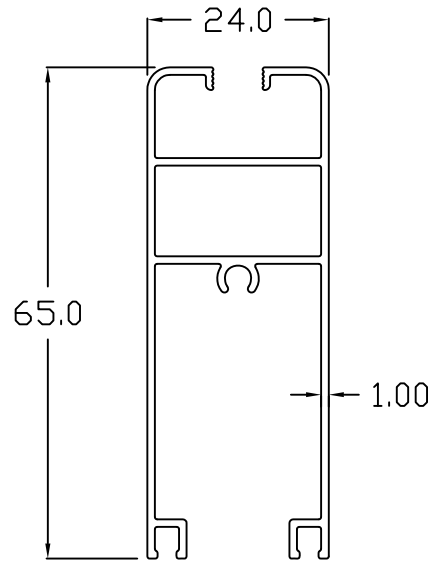

90005
BOTTOM RAIL



YC SECTIONS

TELS. 8983 - 2732 ,
3445 - 4989 ,
8990 - 7364
FAX.No. 3432 - 4324

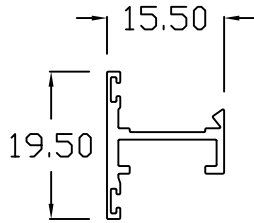

YC-1
Transom Bar

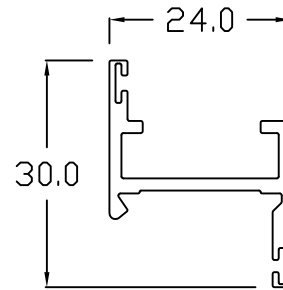

YC-2
Vent Frame Panel

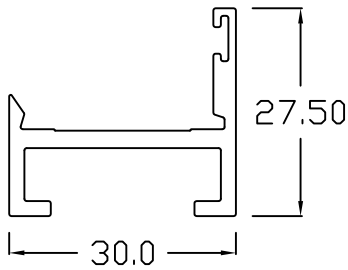

YC-2A
Perimeter Frame

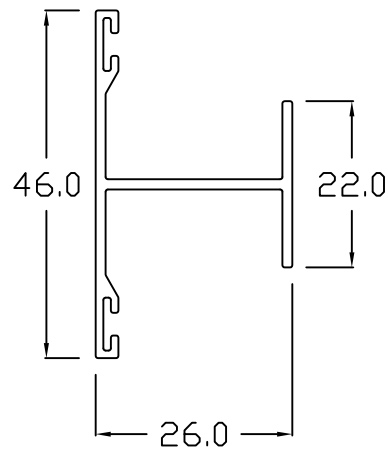

YC-4
Center Frame

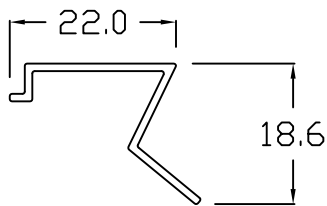

YC-12
Moulding

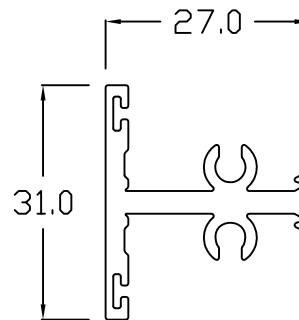

YC-16
Muntin



YC SECTIONS

TELS. 8983 - 2732 ,
3445 - 4989 ,
8990 - 7364
FAX.No. 3432 - 4324

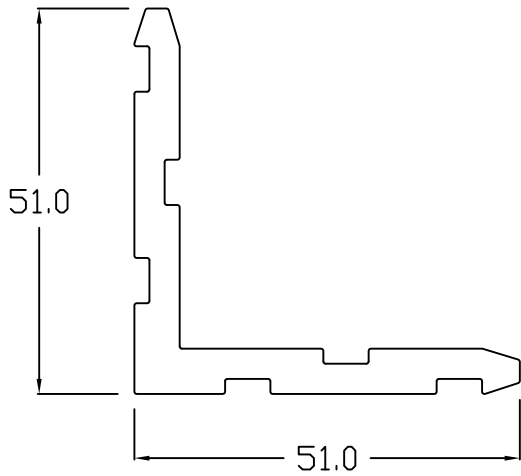

PC - 11288
Cornerstake 2 X 2

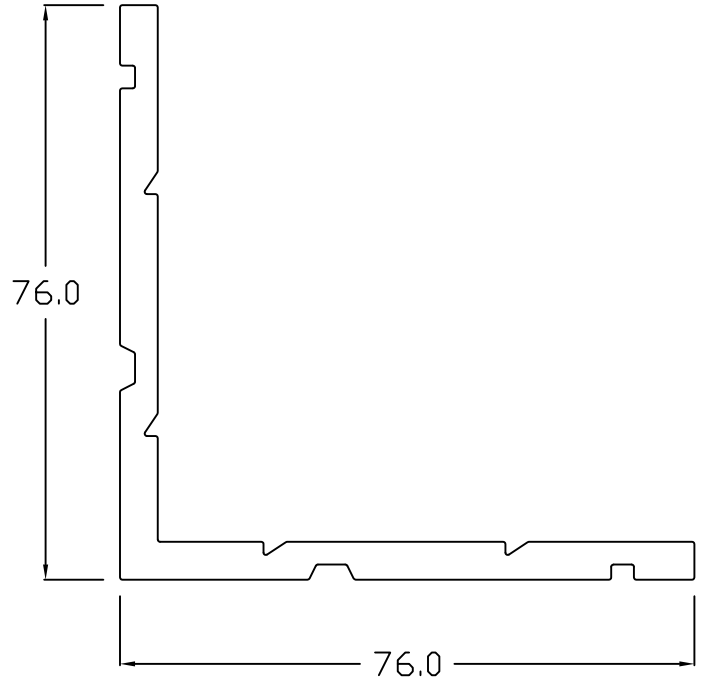

YC-17
Cornerstake 3 X 3

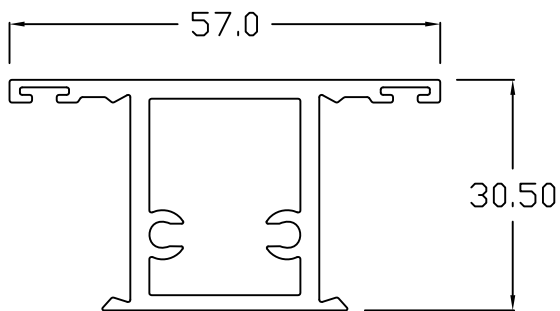

YC-18
Center Mullion

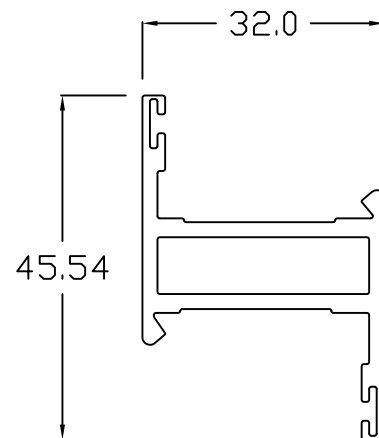

YC-19
YC2 TUBULAR



LYC SECTIONS

TELS. 8983 - 2732 ,
3445 - 4989 ,
8990 - 7364
FAX.No. 3432 - 4324

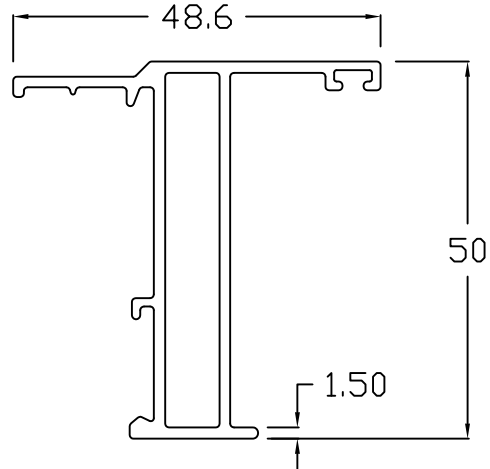

LYC - 2

PANEL FRAME
(ORDINARY LOCK)

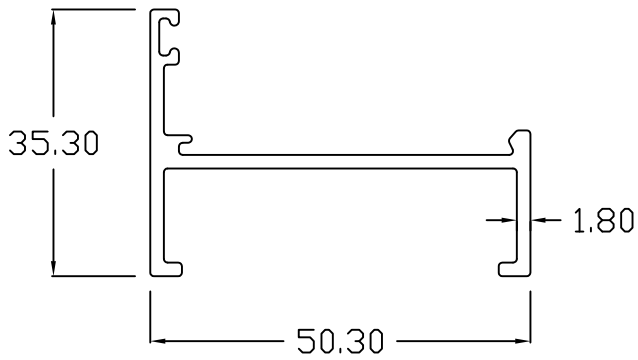

LYC - 2A

PERIMETER FRAME

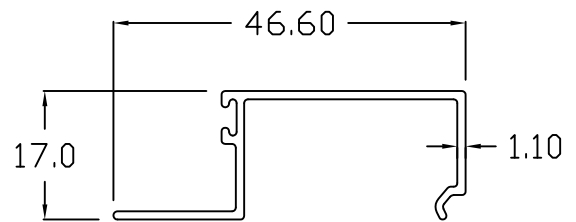

LYC - 13

GLAZING BEAD CLIP



LYC SECTIONS

TELS. 8983 - 2732 ,
3445 - 4989 ,
8990 - 7364
FAX.No. 3432 - 4324

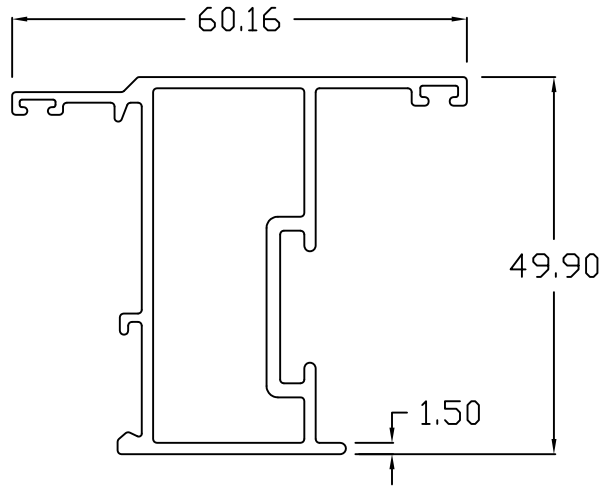

LYC - 2B
PANEL FRAME
(MULTI - POINT LOCK)

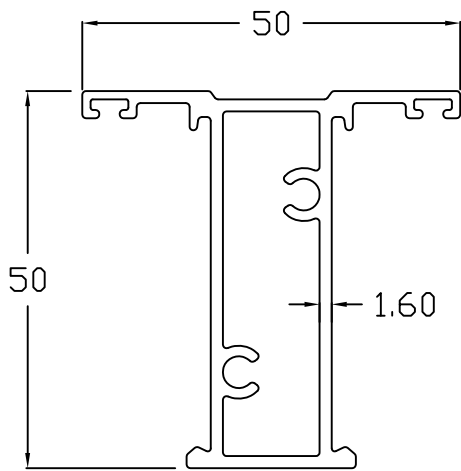

LYC - 4
CENTER MULLION

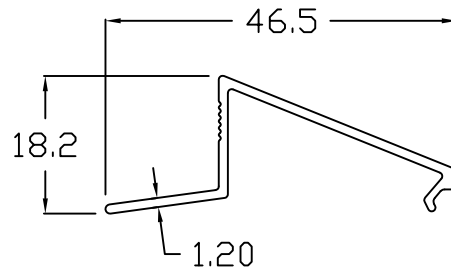

LYC - 12



CLEO SECTIONS

TELS.No.7586 - 8309 ,
8990 - 7364
CP.No. 09171838309
FAX.No. 8983 - 2732

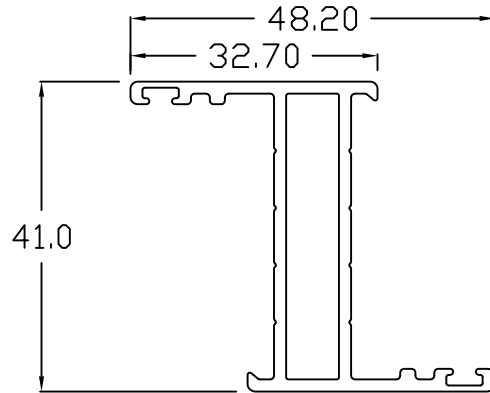

CLEO 46
YC Heavy Duty vent frame

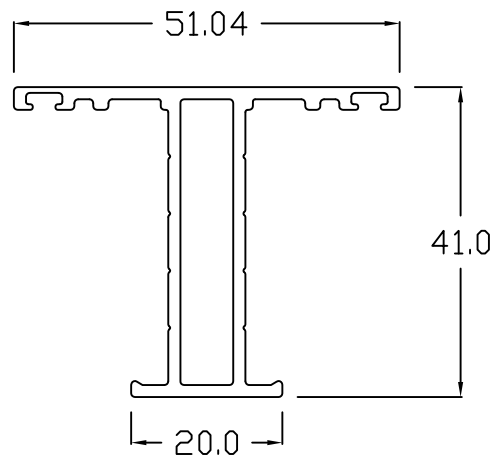

CLEO 47
YC Heavy Duty center panel



CLEO SECTIONS

TELS.No.7586 - 8309 ,
8990 - 7364
CP.No. 09171838309
FAX.No. 8983 - 2732

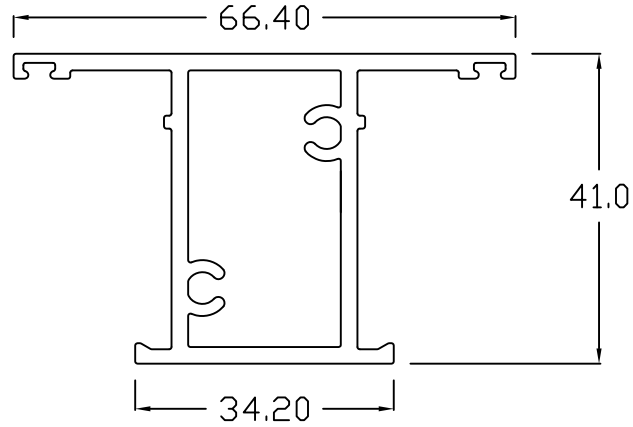

CLEO 48

YC Heavy Duty post

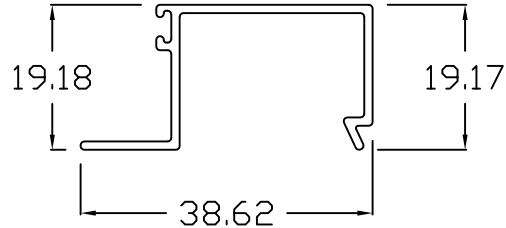

CLEO 49

YC Heavy Duty molding

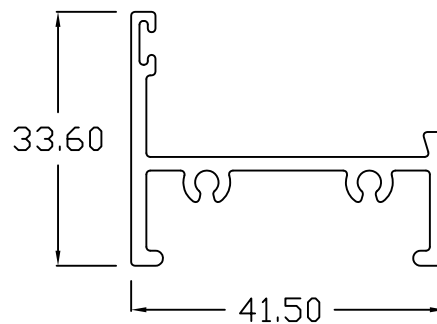

CLEO 50

YC Heavy Duty perimeter



STOREFRONT SECTIONS

TELS.No.7586 - 8309 ,
8990 - 7364
CP.No. 09171838309
FAX.No. 8983 - 2732

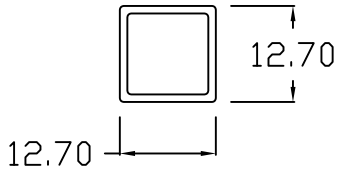

SQ.TUBE - 1/2 x 1/2

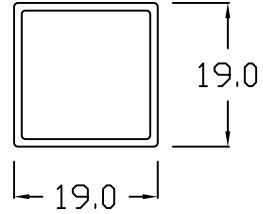

SQ. TUBE - 3/4 x 3/4

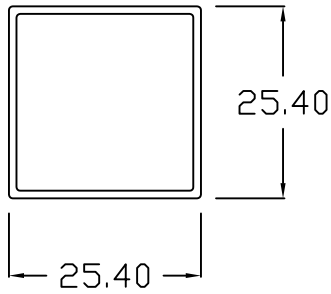

SQ. TUBE - 1 x 1

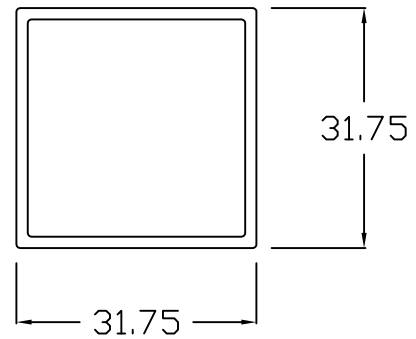

SQ. TUBE - 1 1/4 x 1 1/4

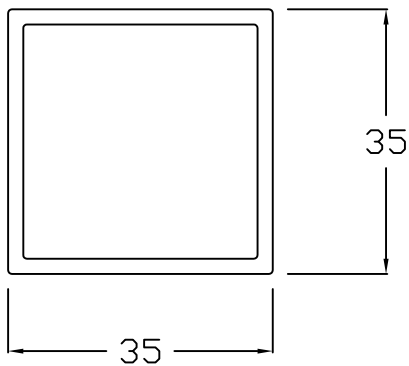

SQ. TUBE - 1 3/8 x 1 3/8

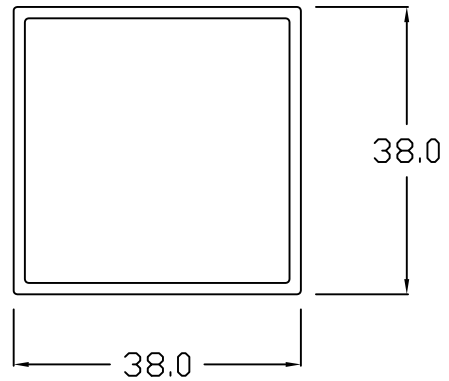

SQ. TUBE - 1 1/2 x 1 1/2



STOREFRONT SECTIONS

TELS.No.7586 - 8309 ,
8990 - 7364
CP.No. 09171838309
FAX.No. 8983 - 2732

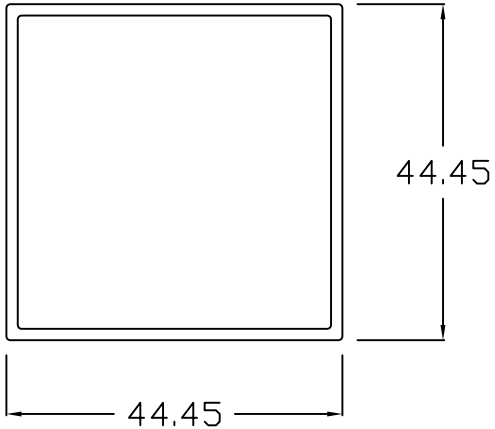

SQ. TUBE - 1 3/4 x 1 3/4

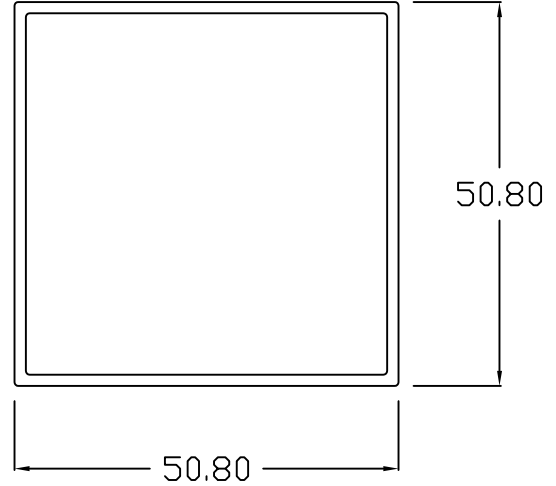

SQ. TUBE - 2 x 2

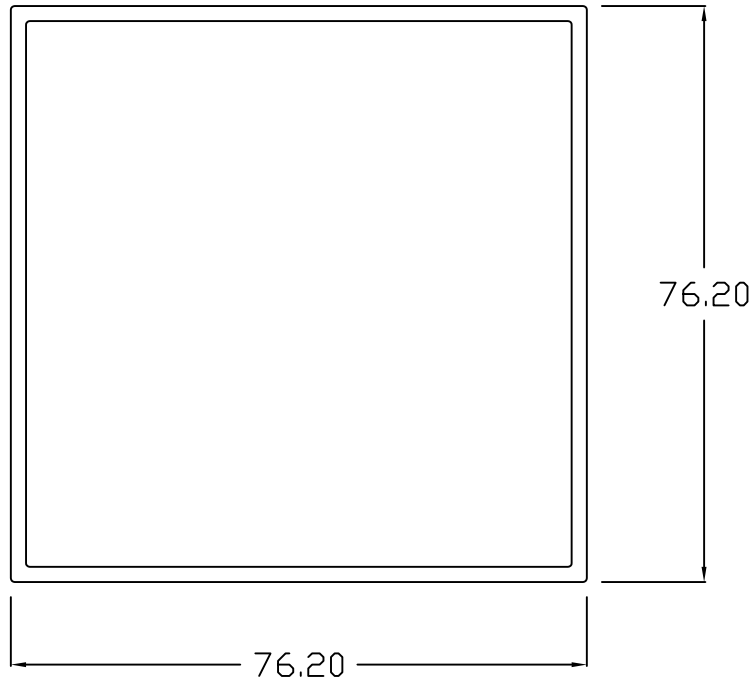

SQ. TUBE - 3 x 3



STOREFRONT SECTIONS

TELS.No. 7586 - 8309 ,
8990 - 7364
CP.No. 09171838309
FAX.No. 8983 - 2732

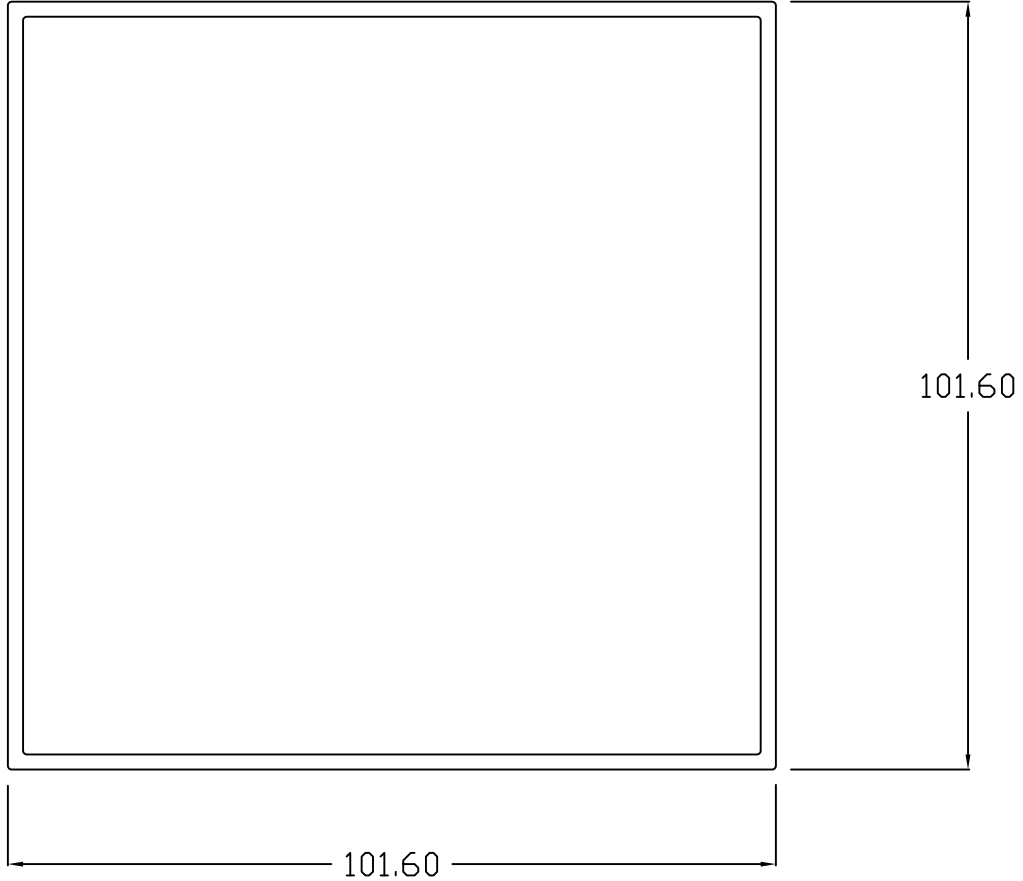

SQ. TUBE - 4 x 4

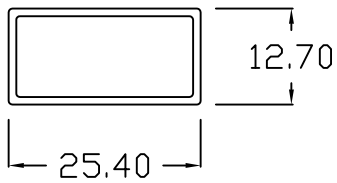

RECT. TUBE - 1 x 1/2

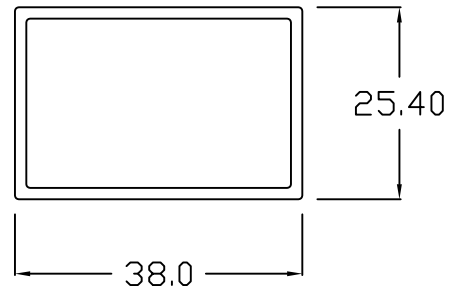

RECT. TUBE - 1 x 1 1/2



STOREFRONT SECTIONS

TELS.No.7586 - 8309 ,
8990 - 7364
CP.No. 09171838309
FAX.No. 8983 - 2732

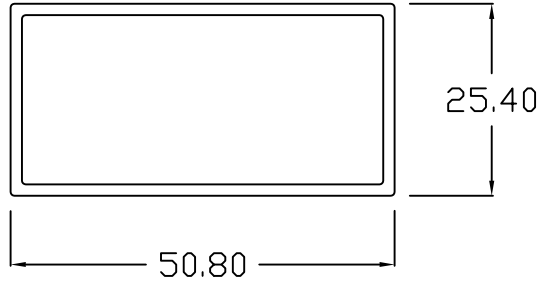

RECT. TUBE - 1 x 2

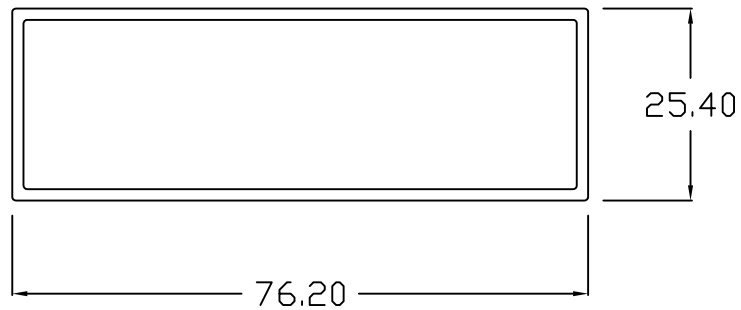

RECT. TUBE - 1 x 3

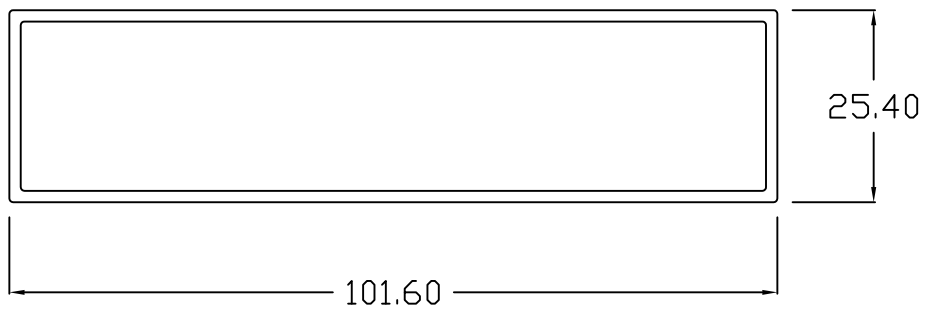

RECT. TUBE - 1 x 4



STOREFRONT SECTIONS

TELS.No.7586 - 8309 ,
8990 - 7364
CP.No. 09171838309
FAX.No. 8983 - 2732

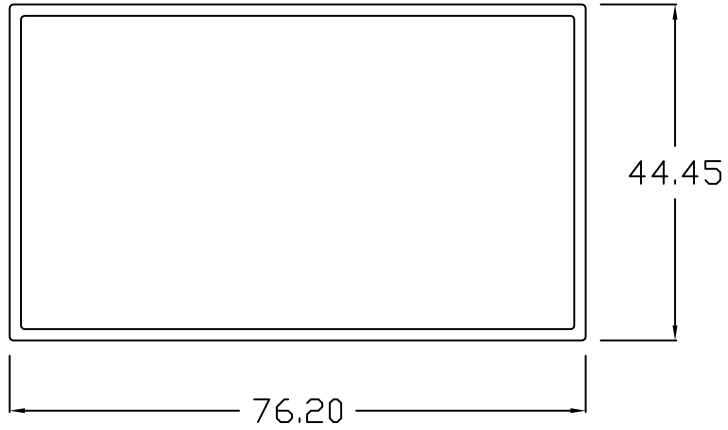

RECT. TUBE - 1 3/4 x 3

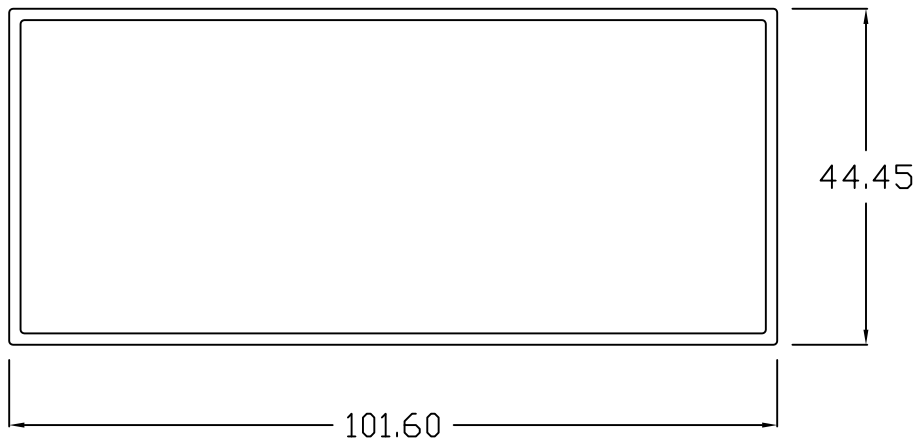

RECT. TUBE - 1 3/4 x 4



STOREFRONT SECTIONS

TELS.No.7586 - 8309 ,
8990 - 7364
CP.No. 09171838309
FAX.No. 8983 - 2732

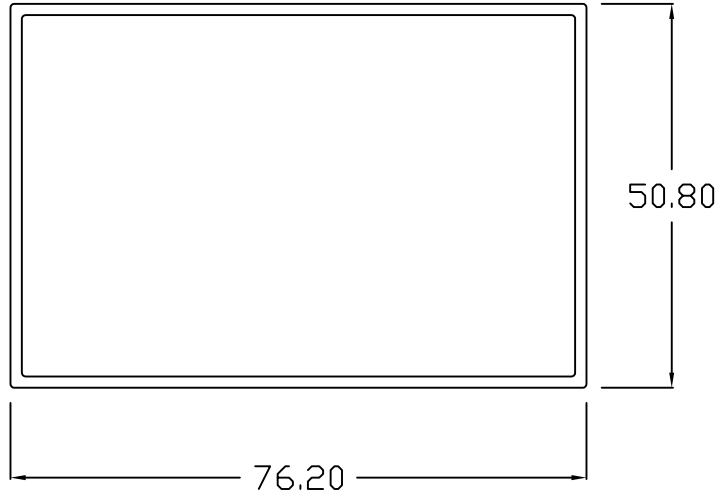

RECT. TUBE - 2 x 3

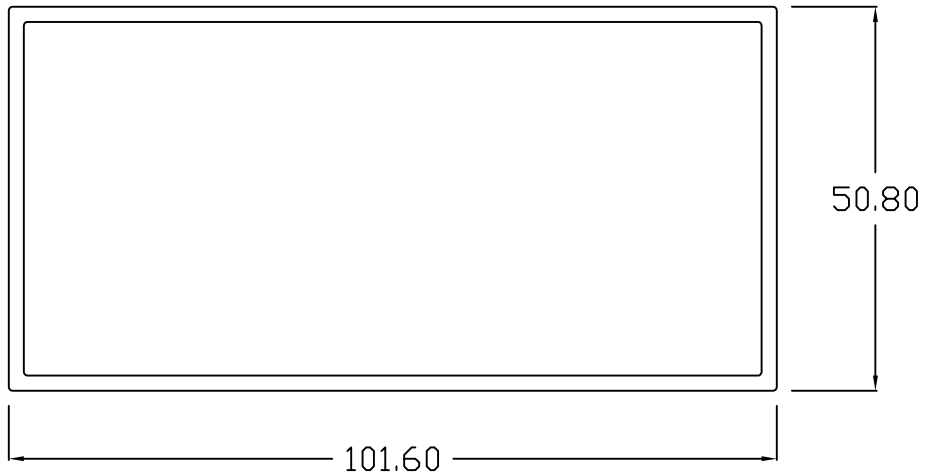

RECT. TUBE - 2 x 4



STOREFRONT SECTIONS

TELS.No.7586 - 8309 ,
8990 - 7364
CP.No. 09171838309
FAX.No. 8983 - 2732

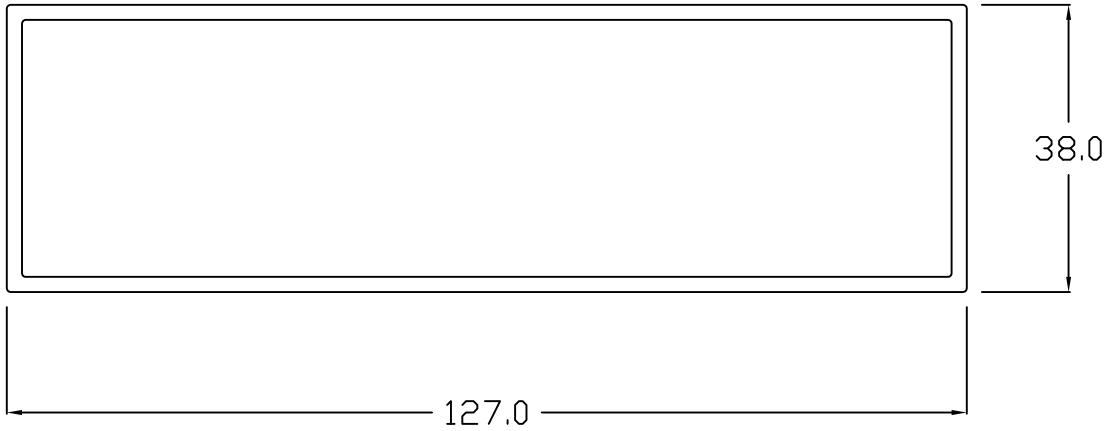

RECT. TUBE - 1 1/2 x 5

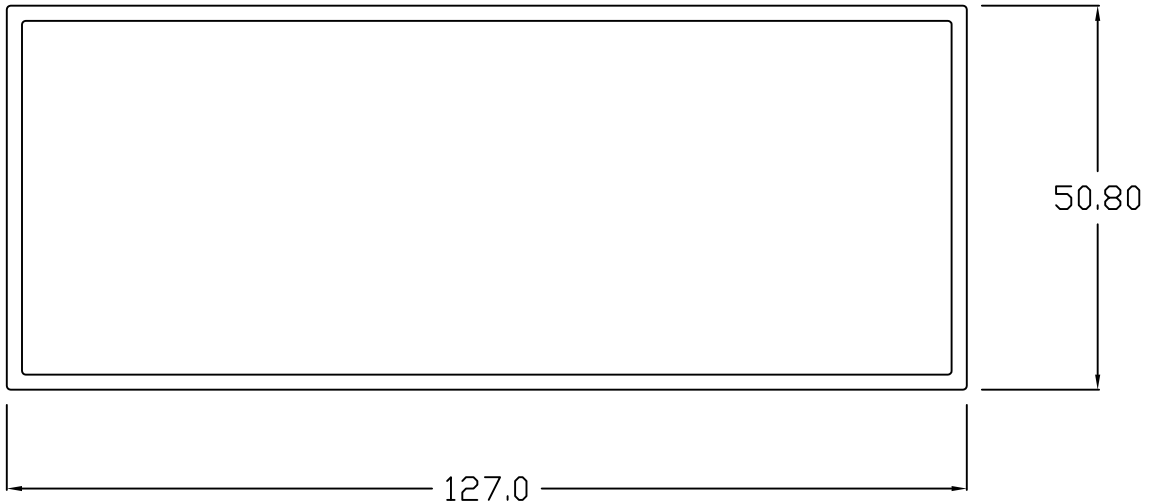

RECT. TUBE - 2 x 5



STOREFRONT SECTIONS

TELS.No.7586 - 8309 ,
8990 - 7364
CP.No. 09171838309
FAX.No. 8983 - 2732

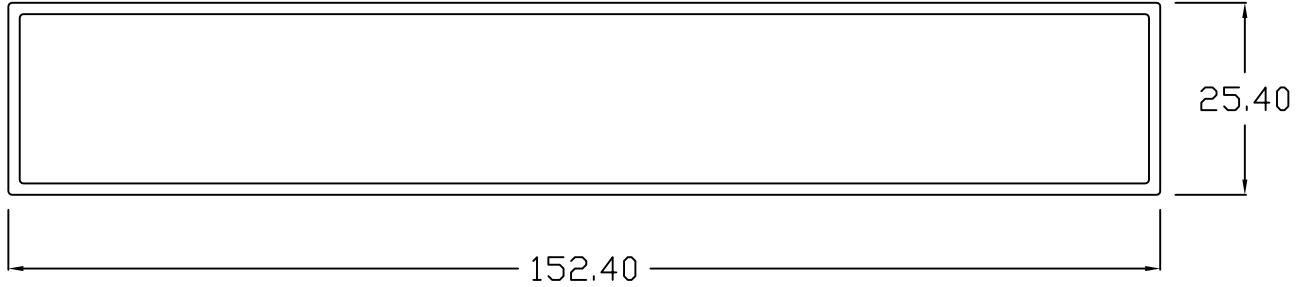

RECT. TUBE - 1 x 6

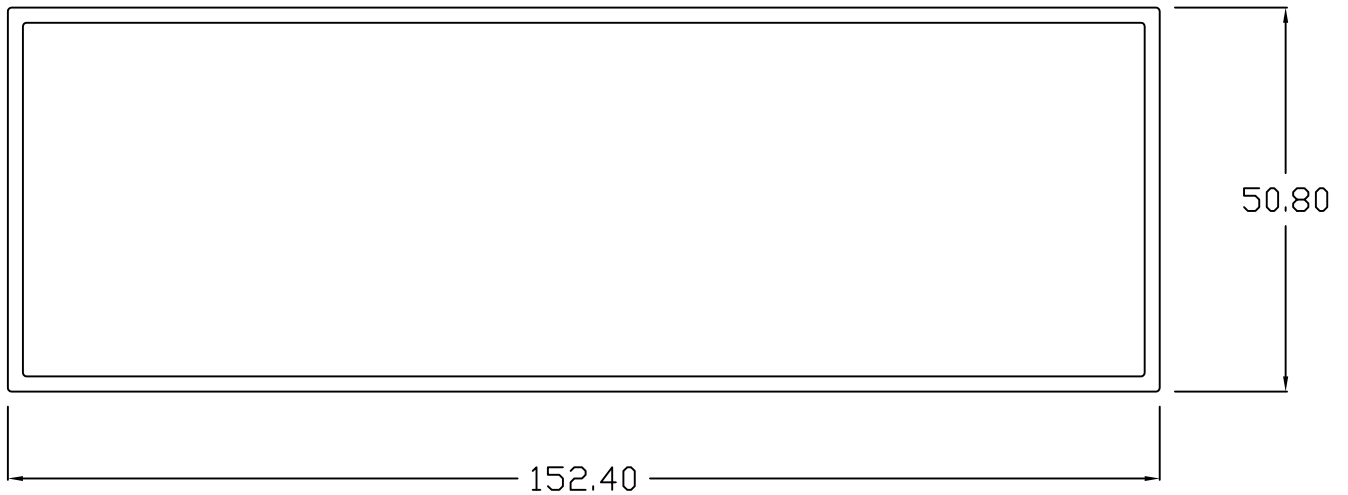

RECT. TUBE - 2 x 6



STOREFRONT SECTIONS

TELS.No.7586 - 8309 ,
8990 - 7364
CP.No. 09171838309
FAX.No. 8983 - 2732

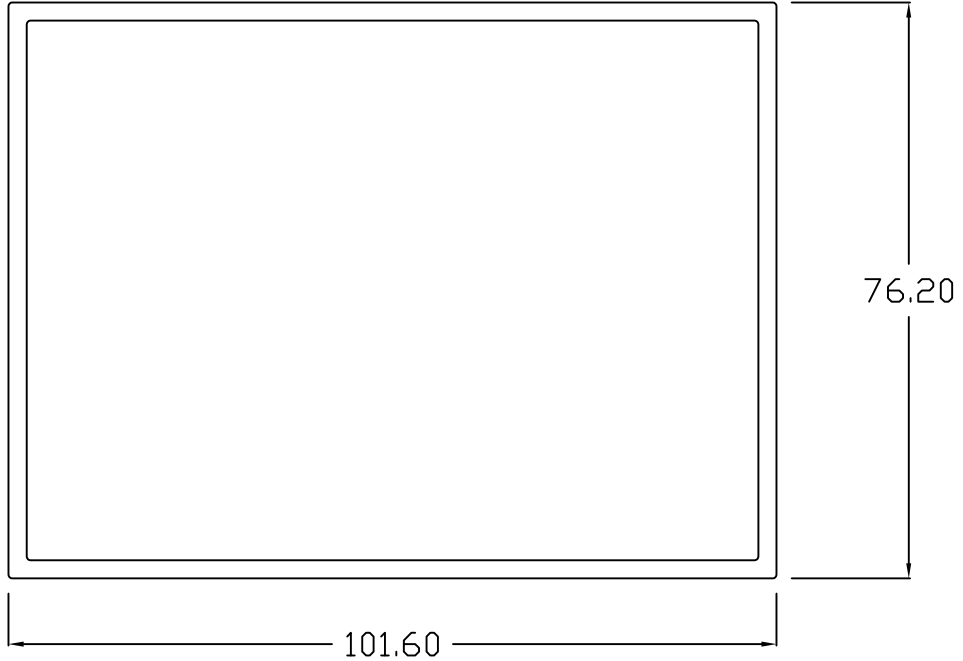

RECT. TUBE - 3 x 4

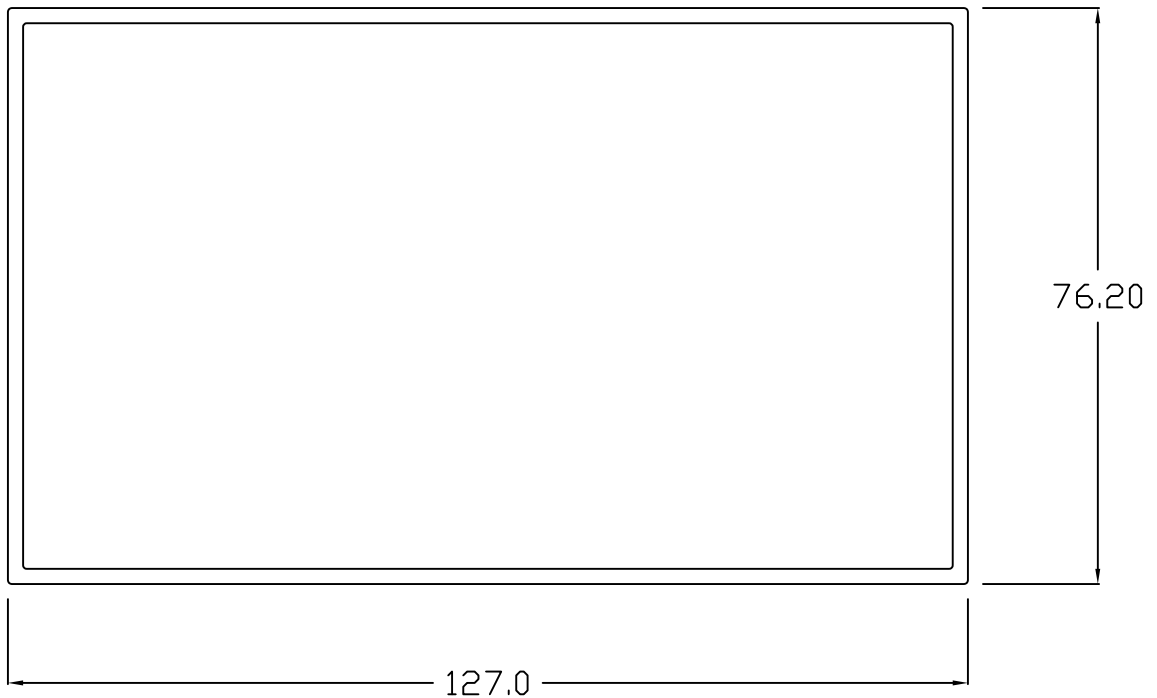

RECT. TUBE - 3 x 5



STOREFRONT SECTIONS

TELS.No. 7586 - 8309 ,
8990 - 7364
CP.No. 09171838309
FAX.No. 8983 - 2732



RECT. TUBE - 3 x 6

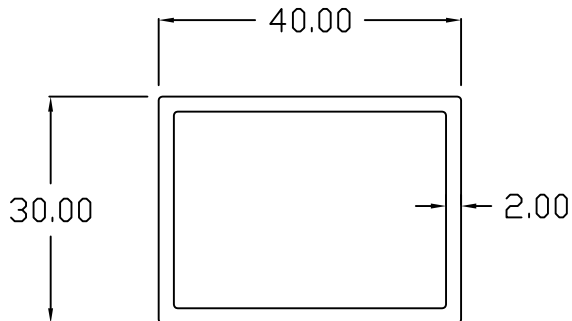

RECT. TUBE - 30mm x 40mm



STOREFRONT SECTIONS

TELS.No. 7586 - 8309 ,
8990 - 7364
CP.No. 09171838309
FAX.No. 8983 - 2732



RECT. TUBE - 70mm x 140mm

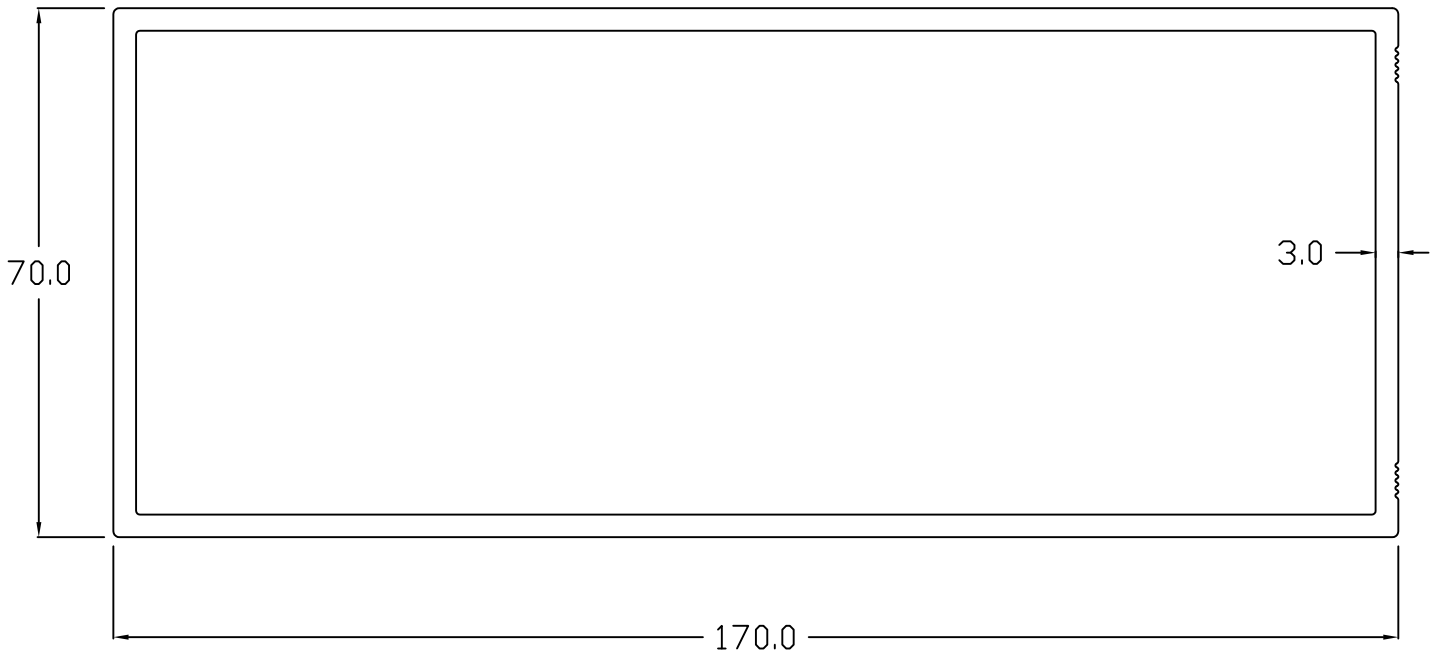

RECT. TUBE - 70mm x 170mm

TUBULAR W/ DESIGN



STOREFRONT SECTIONS

TELS.No.7586 - 8309 ,
8990 - 7364
CP.No. 09171838309
FAX.No. 8983 - 2732

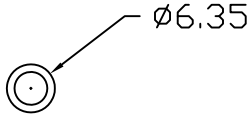

ROUND TUBE - 1/4

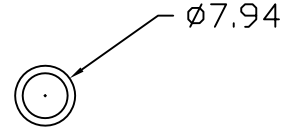

ROUND TUBE - 5/16

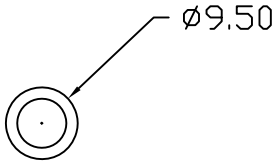

ROUND TUBE - 3/8

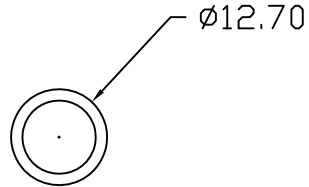

ROUND TUBE - 1/2

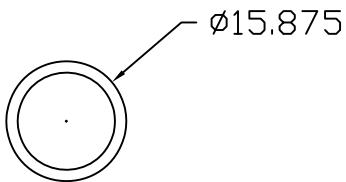

ROUND TUBE - 5/8

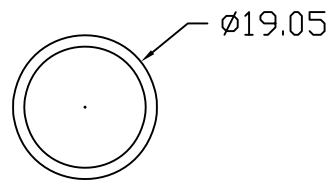

ROUND TUBE - 3/4

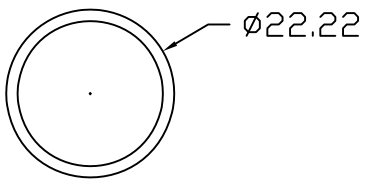

ROUND TUBE - 7/8

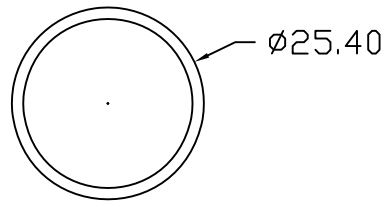

ROUND TUBE - 1"



STOREFRONT SECTIONS

TELS.No.7586 - 8309 ,
8990 - 7364
CP.No. 09171838309
FAX.No. 8983 - 2732

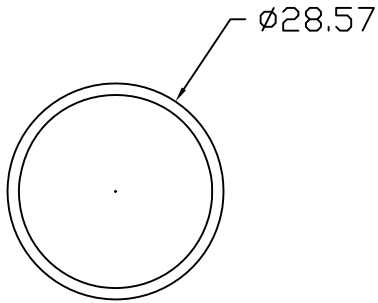

ROUND TUBE - 1 1/8

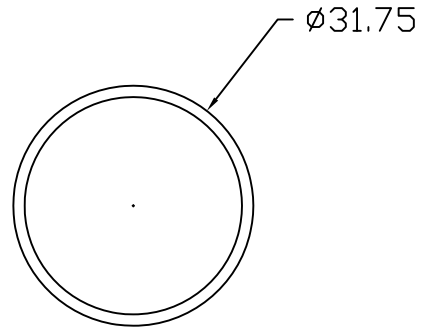

ROUND TUBE - 1 1/4

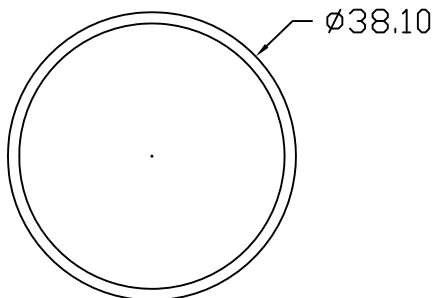

ROUND TUBE - 1 1/2

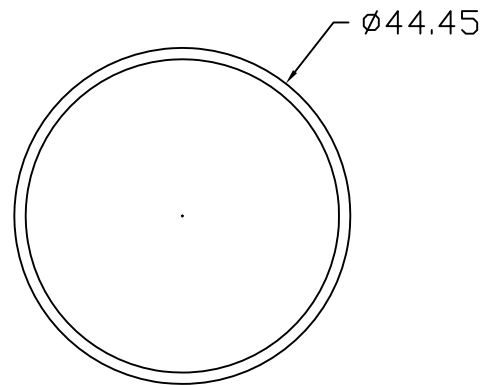

ROUND TUBE 1 3/4

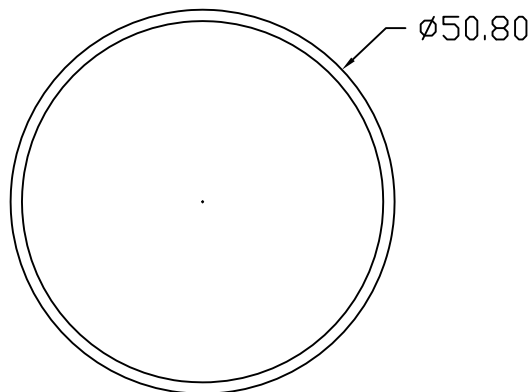

ROUND TUBE - 2"



ANGLE SECTIONS

TELS. 8983 - 2732 ,
3445 - 4989 ,
8990 - 7364
FAX.No. 3432 - 4324

available : THICKNESS

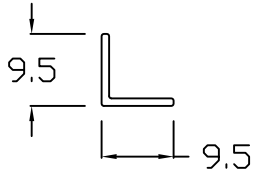

ANGLE - 3/8 x 3/8

available : 1mm

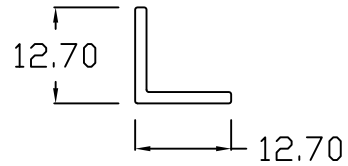

ANGLE - 1/2 x 1/2

available : 1mm - 3mm

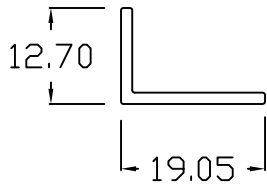

ANGLE - 1/2 x 3/4

available : 1mm

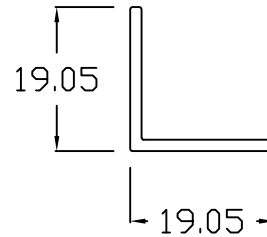

ANGLE - 3/4 x 3/4

available : 1mm - 6mm

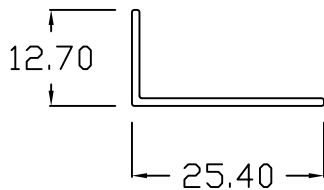

ANGLE - 1/2 x 1

available : 1mm

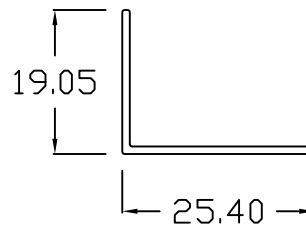

ANGLE - 3/4 x 1

available : 1mm



STOREFRONT SECTIONS

TELS.No.7586 - 8309 ,
8990 - 7364
CP.No. 09171838309
FAX.No. 8983 - 2732

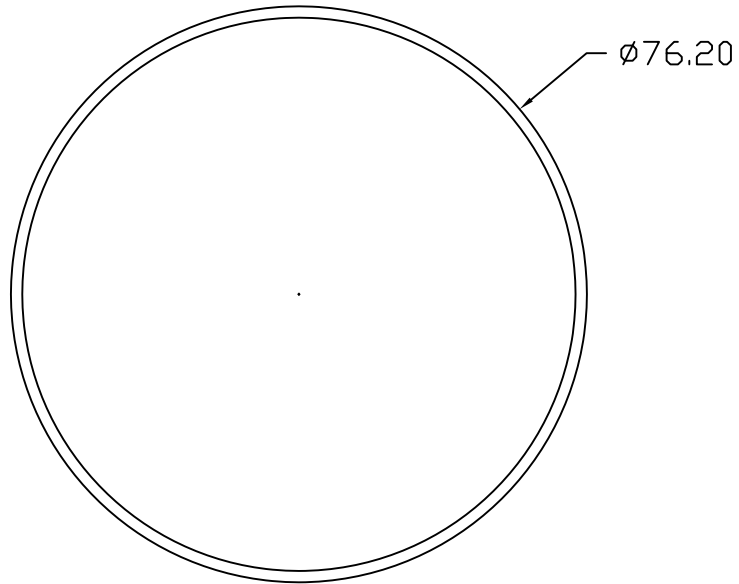

ROUND TUBE - 3"

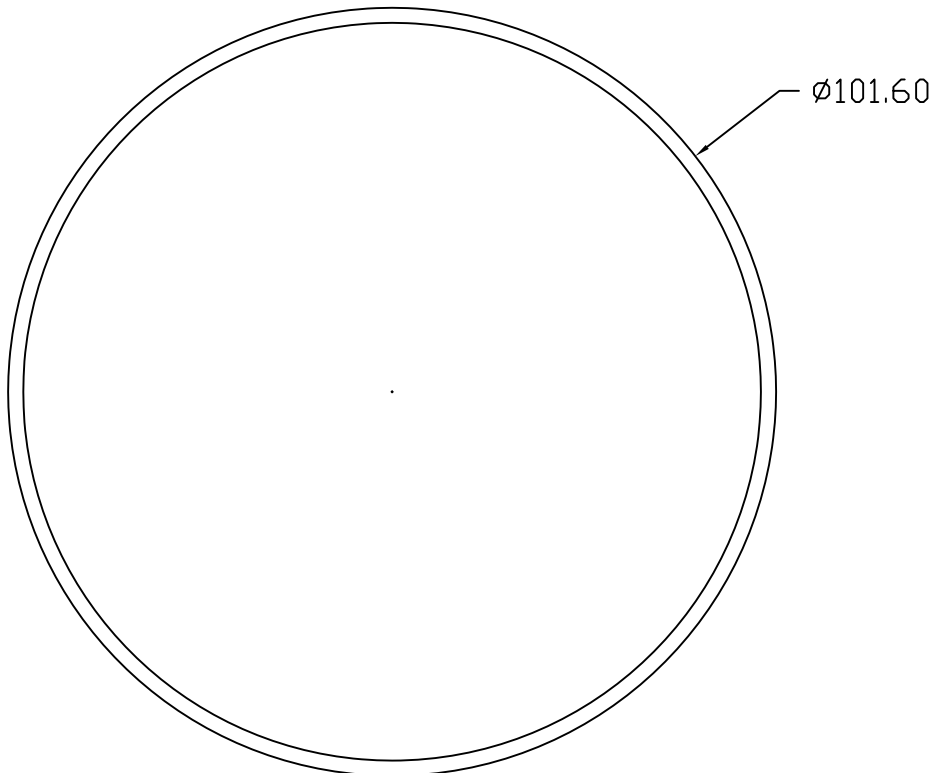

ROUND TUBE - 4"

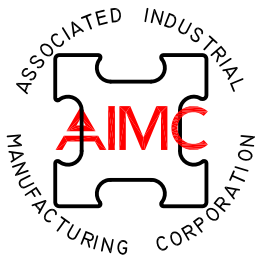

STOREFRONT SECTIONS

TELS.No.7586 - 8309 ,
8990 - 7364
CP.No. 09171838309
FAX.No. 8983 - 2732

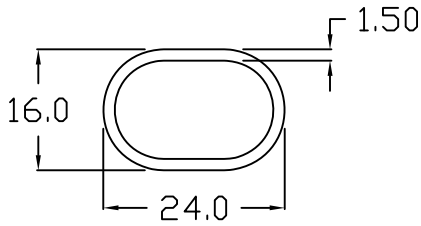

OVAL TUBE - 16mm x 24mm

available thickness : 1.5mm

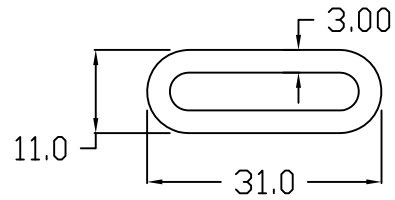

OVAL TUBE - 11mm x 31mm

available thickness : 3mm

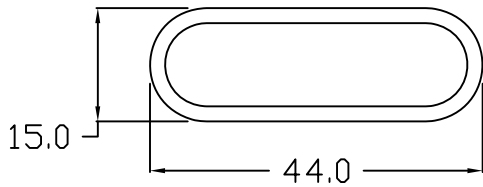

OVAL TUBE - 15mm x 44mm

available thickness : 2mm

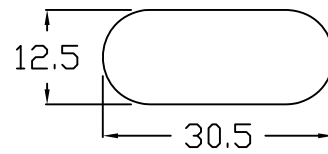

12.5mm x 30.5mm

SOLID OVAL



STOREFRONT SECTIONS

TELS.No.7586 - 8309 ,
8990 - 7364
CP.No. 09171838309
FAX.No. 8983 - 2732

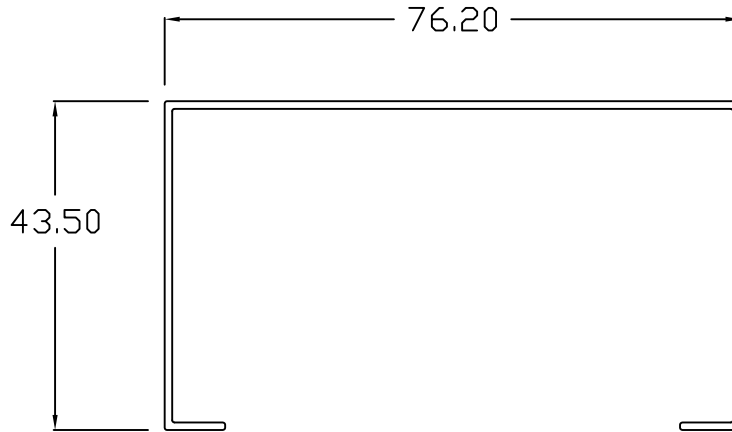

OB - 300

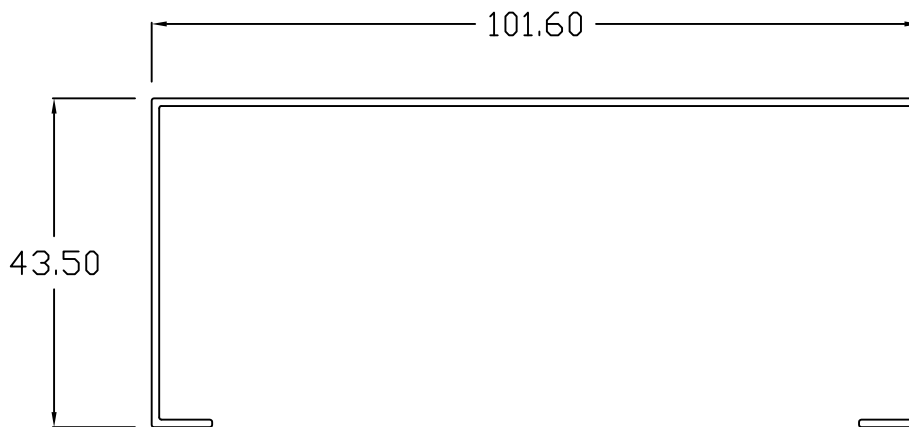

OB - 400



STOREFRONT SECTIONS

TELS.No. 7586 - 8309 ,
8990 - 7364
CP.No. 09171838309
FAX.No. 8983 - 2732

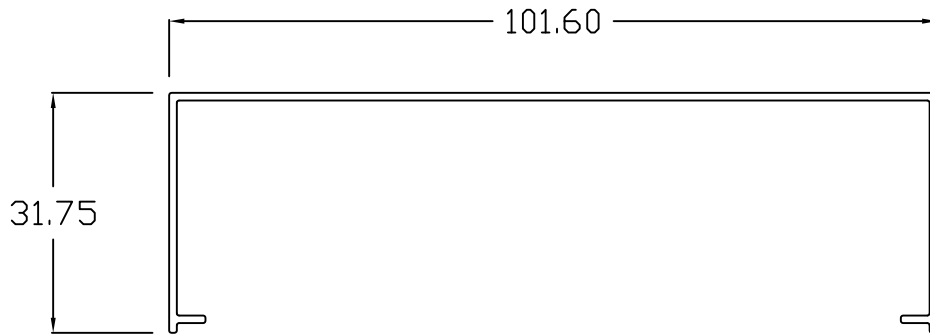

EF - 111C
SPLIT TUBE

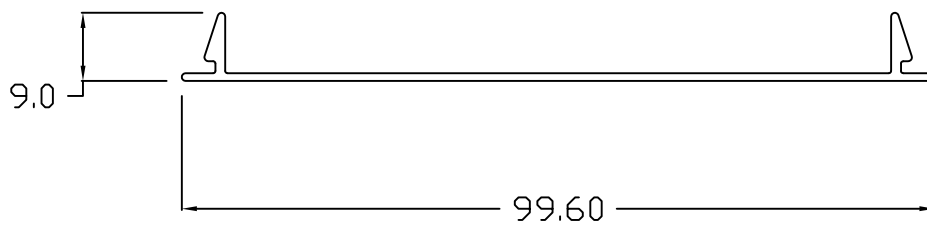

EF - 111D
SPLIT TUBE COVER



ANGLE SECTIONS

TELS.No.7586 - 8309 ,
8990 - 7364
CP.No. 09171838309
FAX.No. 8983 - 2732

available : THICKNESS

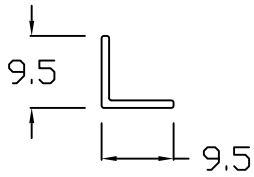

ANGLE - 3/8 x 3/8

available : 1mm

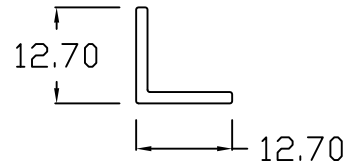

ANGLE - 1/2 x 1/2

available : 1mm - 3mm

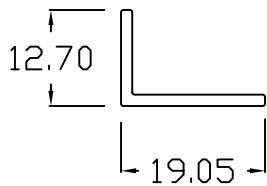

ANGLE - 1/2 x 3/4

available : 1mm

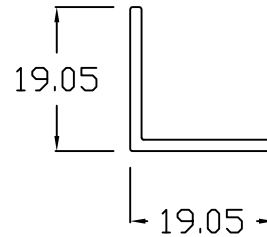

ANGLE - 3/4 x 3/4

available : 1mm - 6mm

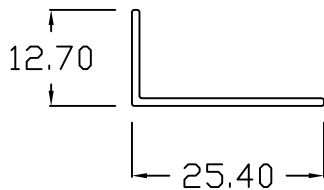

ANGLE - 1/2 x 1

available : 1mm

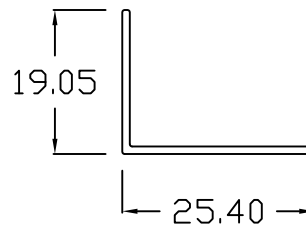

ANGLE - 3/4 x 1

available : 1mm



ANGLE SECTIONS

TELS.No.7586 - 8309 ,
8990 - 7364
CP.No. 09171838309
FAX.No. 8983 - 2732

available : THICKNESS



ANGLE - 1/2 x 1 1/2
available : 1mm

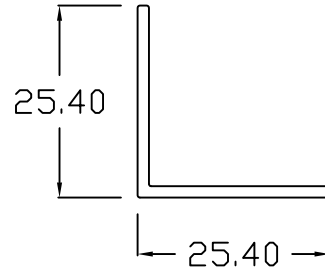

ANGLE - 1 x 1
available : 1mm - 6mm

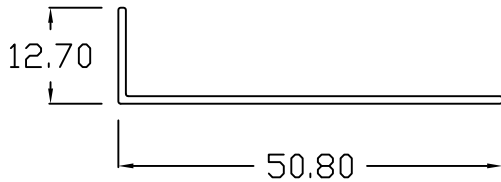

ANGLE - 1/2 x 2
available : 1mm

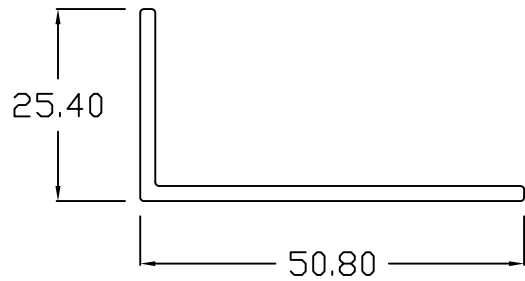

ANGLE - 1 x 2
available : 2mm

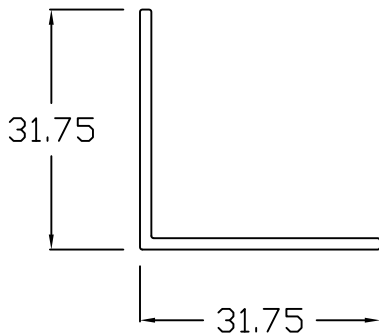

ANGLE - 1 1/4 x 1 1/4
available : 1.5mm - 6mm

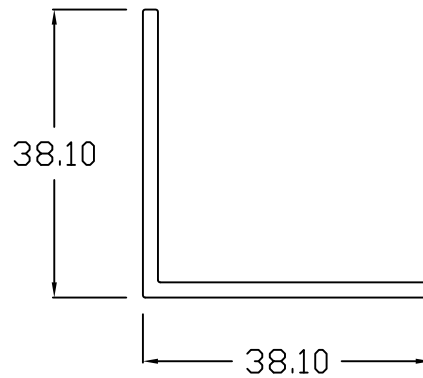

ANGLE - 1 1/2 x 1 1/2
available : 1.5mm - 6mm



ANGLE SECTIONS

TELS.No.7586 - 8309 ,
8990 - 7364
CP.No. 09171838309
FAX.No. 8983 - 2732

available : THICKNESS

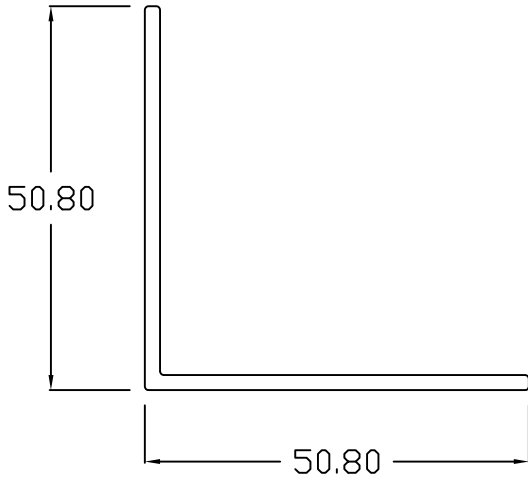

ANGLE - 2 x 2

available : 1.5mm - 6mm

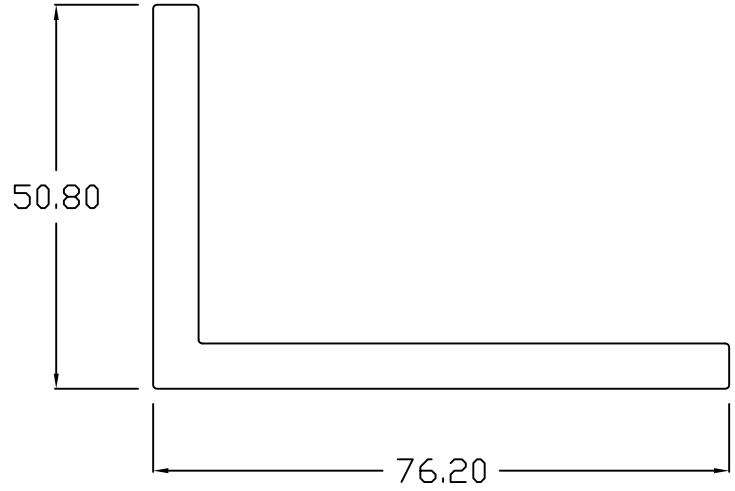

ANGLE - 2 x 3

available : 6mm

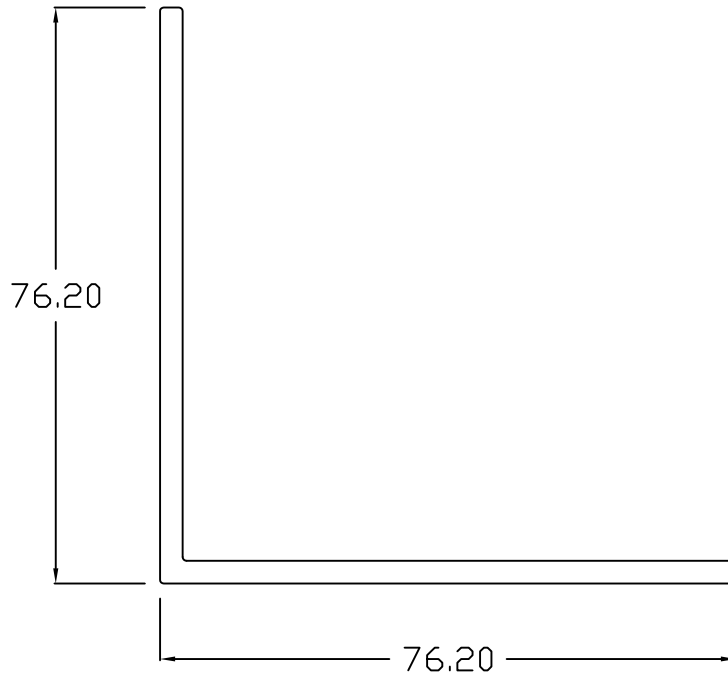

ANGLE - 3 x 3

available : 3mm - 6mm



ANGLE SECTIONS

TELS.No.7586 - 8309 ,
8990 - 7364
CP.No. 09171838309
FAX.No. 8983 - 2732

available : THICKNESS

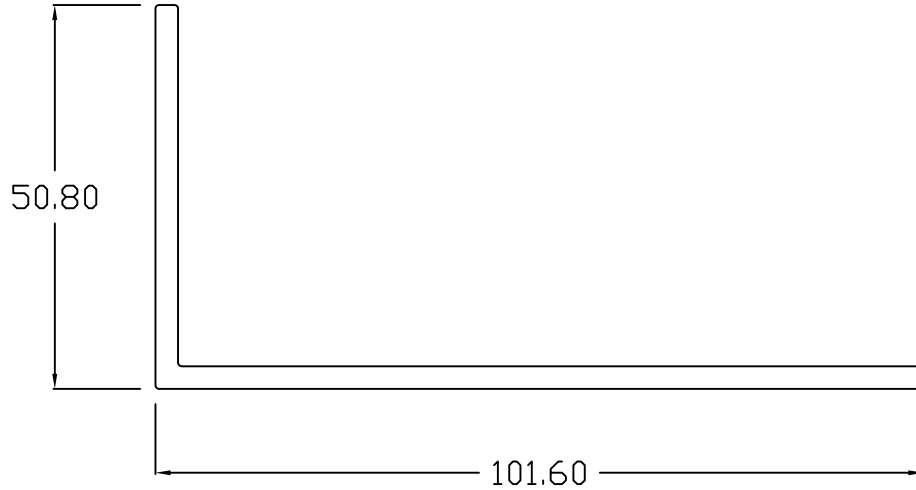

ANGLE - 2 x 4

available : 3mm

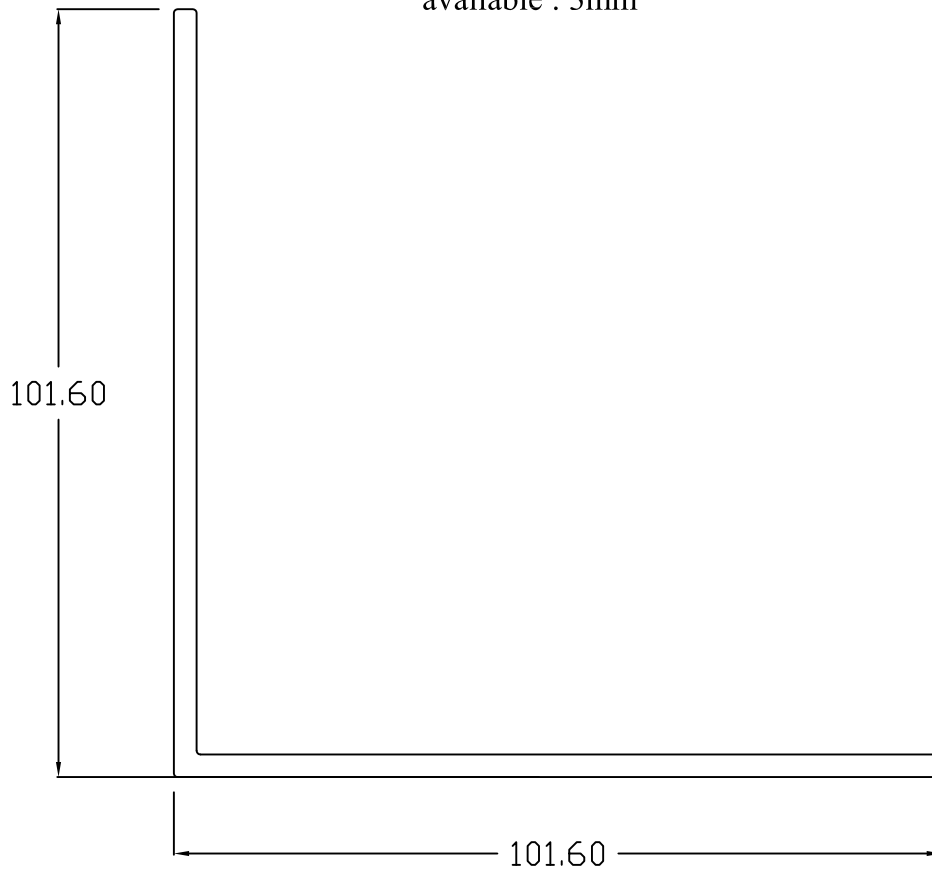

ANGLE - 4 x 4

available : 3mm - 6mm



ANGLE SECTIONS

TELS.No.7586 - 8309 ,
8990 - 7364
CP.No. 09171838309
FAX.No. 8983 - 2732

available : THICKNESS

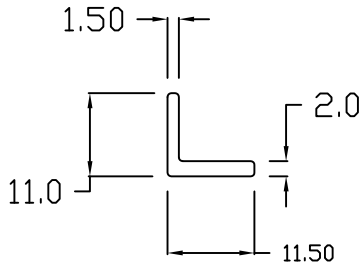

ANGLE - 11mm x 11.5mm

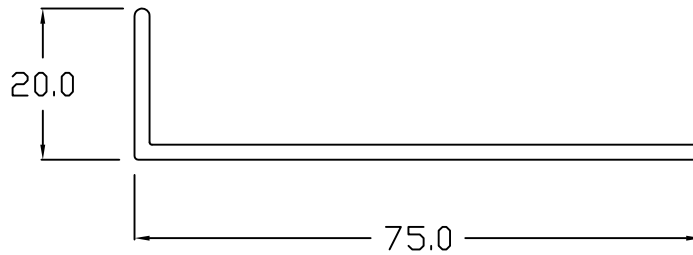

ANGLE - 20mm x 75mm

available : 2 mm

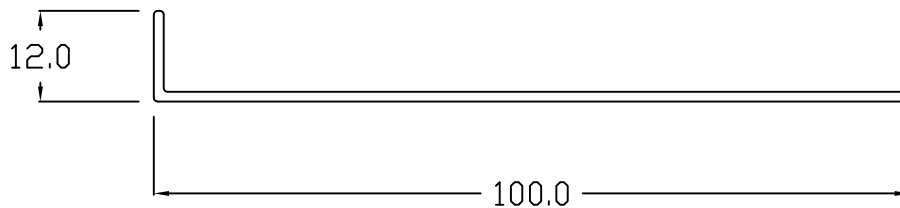

ANGLE - 12mm x 100mm

available : 1.3 mm



FLAT BAR SECTIONS

TELS.No.7586 - 8309 ,
8990 - 7364
CP.No. 09171838309
FAX.No. 8983 - 2732

available : THICKNESS

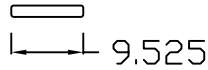

AFB - 3/8

available : 1.5mm

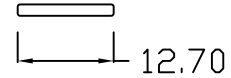

AFB - 1/2

available : 1.5mm - 6mm

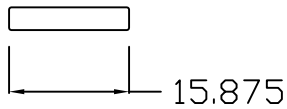

AFB - 5/8

available : 3mm - 6mm

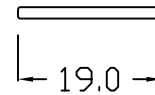

AFB - 3/4

available : 1.5mm - 6mm

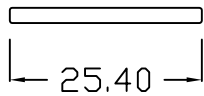

AFB - 1"

available : 1.5mm - 12mm

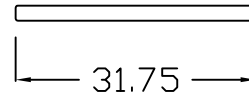

AFB - 1 1/4

available : 1.5mm - 12mm

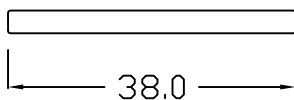

AFB - 1 1/2

available : 1.5mm - 12mm

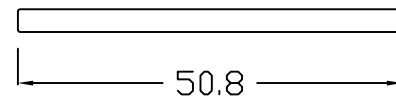

AFB - 2"

available : 1.5mm - 25mm



FLAT BAR SECTIONS

TELS.No.7586 - 8309 ,
8990 - 7364
CP.No. 09171838309
FAX.No. 8983 - 2732

available : THICKNESS

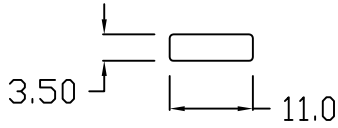

AFB - 11mm x 3.5 mm

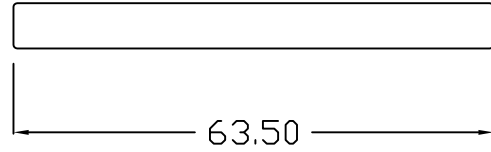

AFB - 2 1/2

available : 6mm

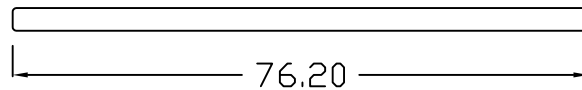

AFB - 3"

available : 3mm - 12mm

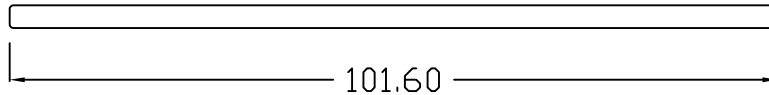

AFB - 4"

available : 3mm - 25mm

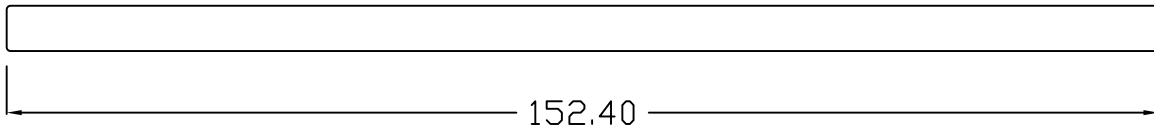

AFB - 6"

available : 6mm - 9mm



SQUARE BAR SECTIONS

TELS. 8983 - 2732 ,
3445 - 4989 ,
8990 - 7364
FAX.No. 3432 - 4324

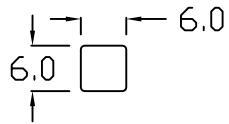

1/4

Tolerance : (+ 0.3mm) (- 0 .3mm)

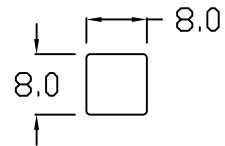

5/16

Tolerance : (+ 0.3mm) (- 0 .3mm)

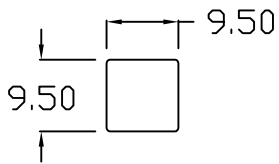

3/8

Tolerance : (+ 0.3mm) (- 0 .3mm)

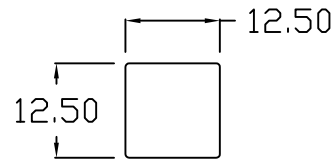

1/2

Tolerance : (+ 0.3mm) (- 0 .3mm)

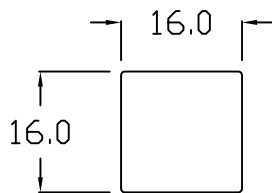

5/8

Tolerance : (+ 0.3mm) (- 0 .3mm)

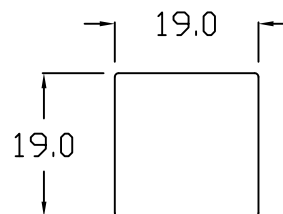

3/4

Tolerance : (+ 0.3mm) (- 0 .3mm)



SQUARE BAR SECTIONS

TELS. 8983 - 2732 ,
3445 - 4989 ,
8990 - 7364
FAX.No. 3432 - 4324

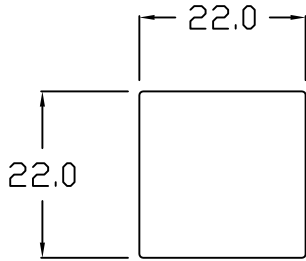

7/8

Tolerance : (+ 0.3mm) (- 0 .3mm)

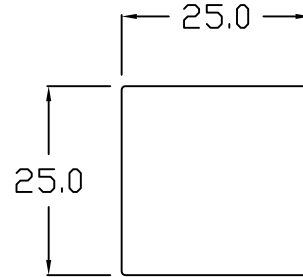

1"

Tolerance : (+ 0.3mm) (- 0 .3mm)

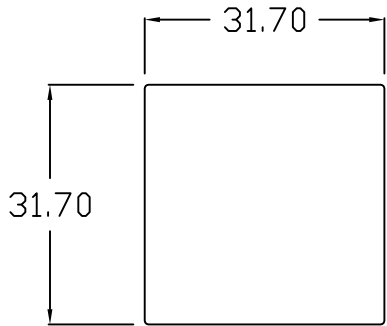

1 1/4

Tolerance : (+ 0.3mm) (- 0 .3mm)

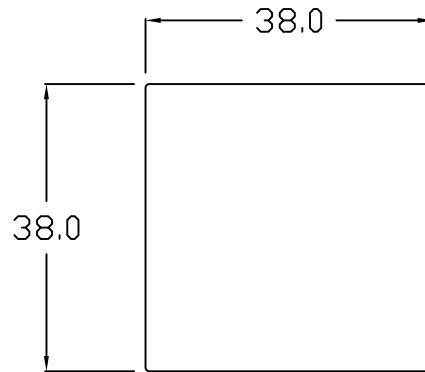

1 1/2

Tolerance : (+ 0.3mm) (- 0 .3mm)

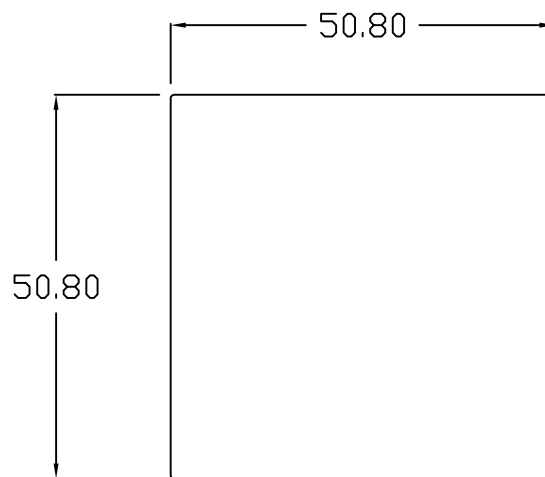

1 1/4

Tolerance : (+ 0.3mm) (- 0 .3mm)



ROUND BAR SECTIONS

TELS. 8983 - 2732 ,
3445 - 4989 ,
8990 - 7364
FAX.No. 3432 - 4324

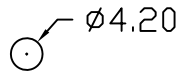

3/16

Tolerance : (+ 0.3mm) (- 0 .3mm)

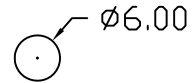

1/4

Tolerance : (+ 0.3mm) (- 0 .3mm)

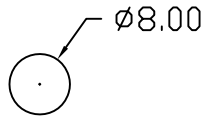

3/8

Tolerance : (+ 0.3mm) (- 0 .3mm)

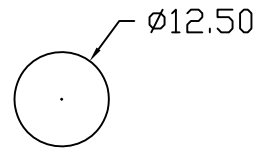

1/2

Tolerance : (+ 0.3mm) (- 0 .3mm)

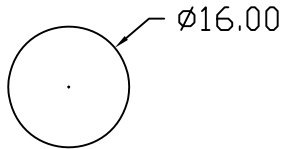

5/8

Tolerance : (+ 0.3mm) (- 0 .3mm)

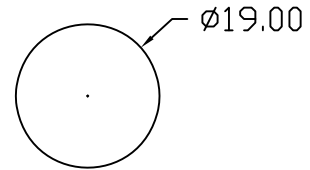

3/4

Tolerance : (+ 0.3mm) (- 0 .3mm)

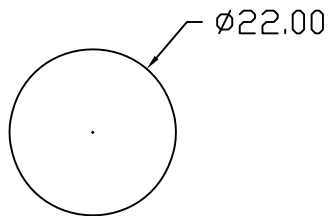

7/8

Tolerance : (+ 0.3mm) (- 0 .3mm)

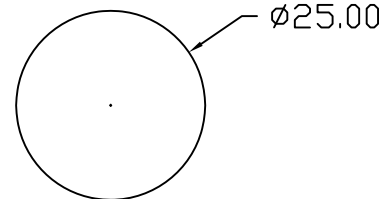

1"

Tolerance : (+ 0.3mm) (- 0 .3mm)



ROUND BAR SECTIONS

TELS. 8983 - 2732 ,
3445 - 4989 ,
8990 - 7364
FAX.No. 3432 - 4324

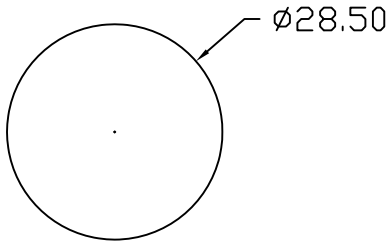

1 1/8

Tolerance : (+ 0.3mm) (- 0.3mm)

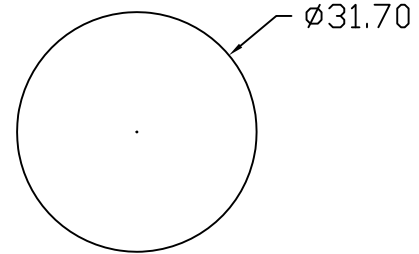

1 1/4

Tolerance : (+ 0.3mm) (- 0.3mm)

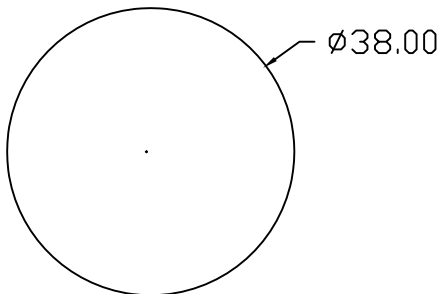

1 1/2

Tolerance : (+ 0.3mm) (- 0.3mm)

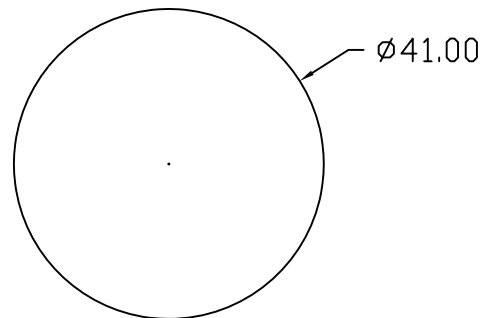

1 5/8

Tolerance : (+ 0.3mm) (- 0.3mm)

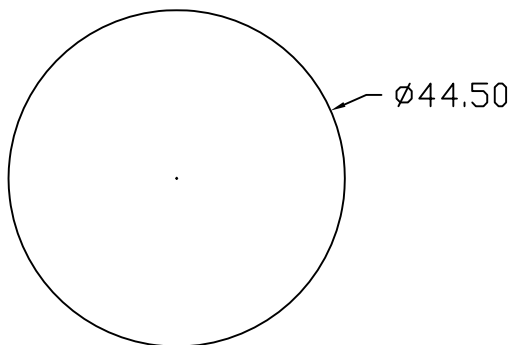

1 3/4

Tolerance : (+ 0.3mm) (- 0.3mm)

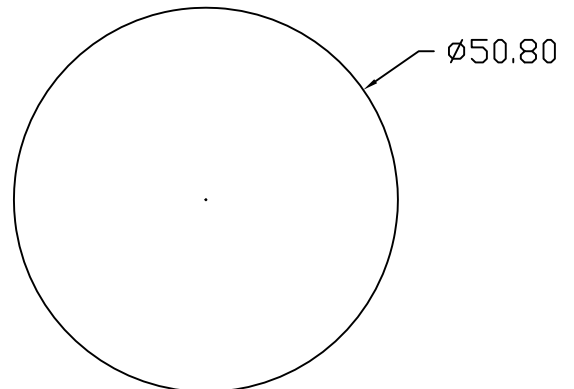

2"

Tolerance : (+ 0.3mm) (- 0.3mm)



ROUND BAR SECTIONS

TELS. 8983 - 2732 ,
3445 - 4989 ,
8990 - 7364
FAX.No. 3432 - 4324

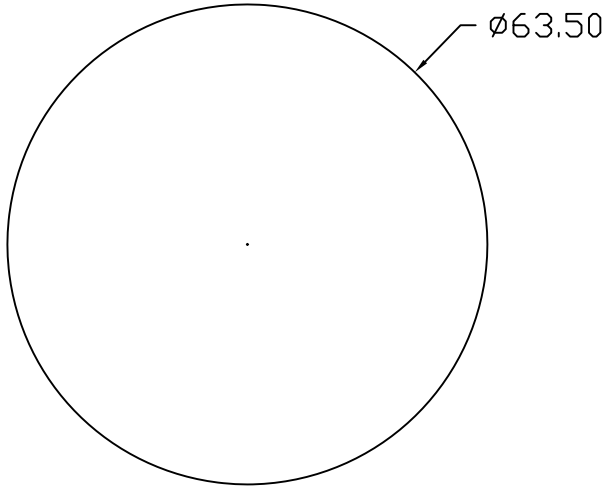

2 1/2

Tolerance : (+ 0.3mm) (- 0 .3mm)

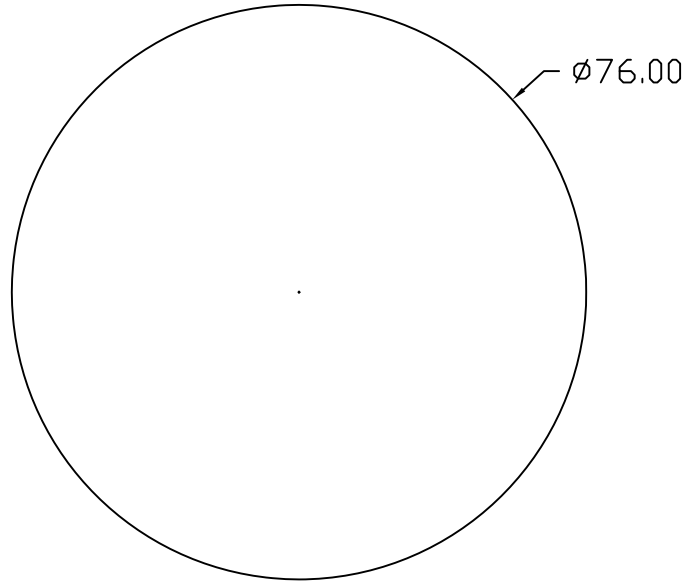

3"

Tolerance : (+ 0.3mm) (- 0 .3mm)

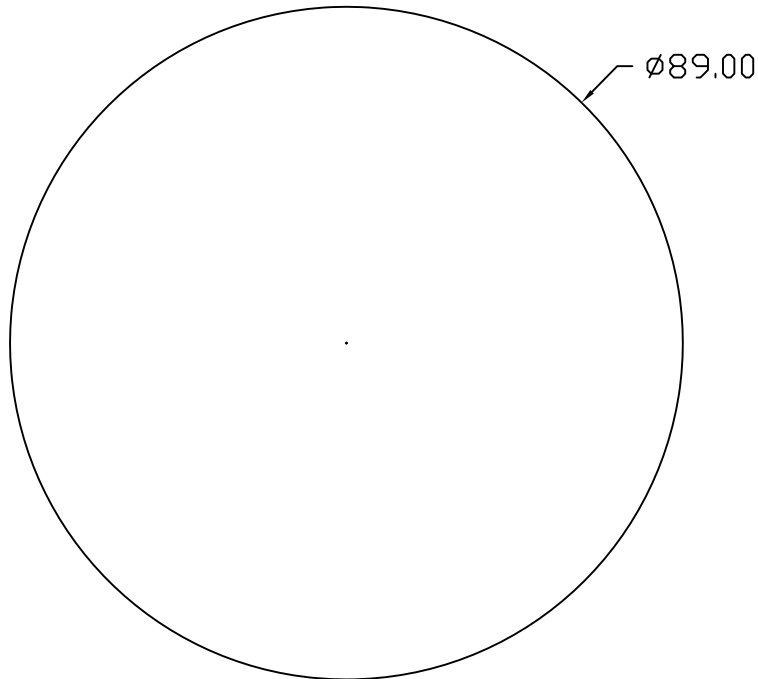

3 1/2

Tolerance : (+ 0.3mm) (- 0 .3mm)



ROUND BAR SECTIONS

TELS. 8983 - 2732 ,
3445 - 4989 ,
8990 - 7364
FAX.No. 3432 - 4324

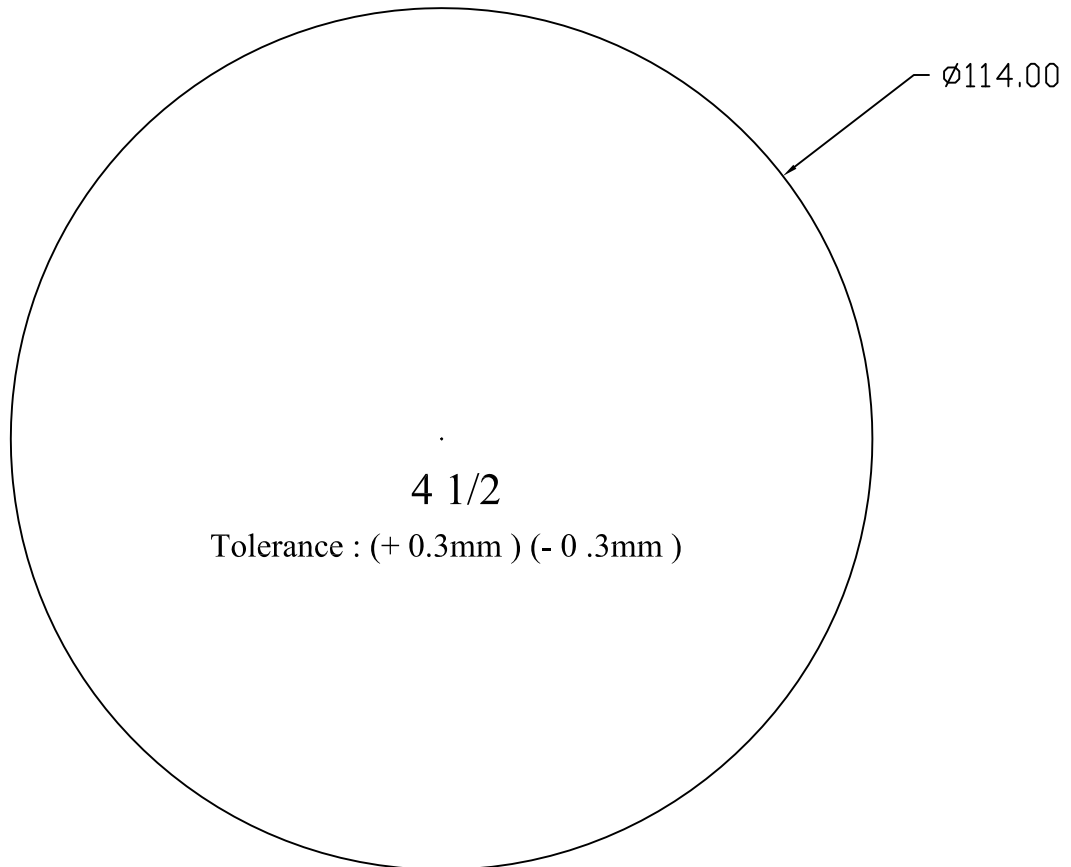
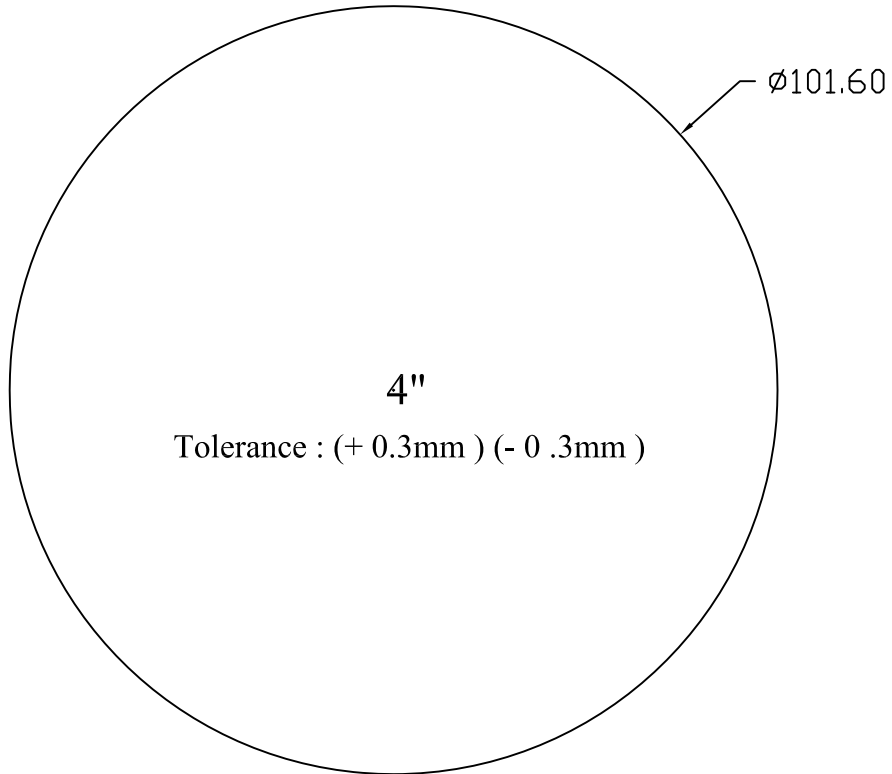



ROUND BAR SECTIONS

TELS. 8983 - 2732 ,
3445 - 4989 ,
8990 - 7364
FAX.No. 3432 - 4324

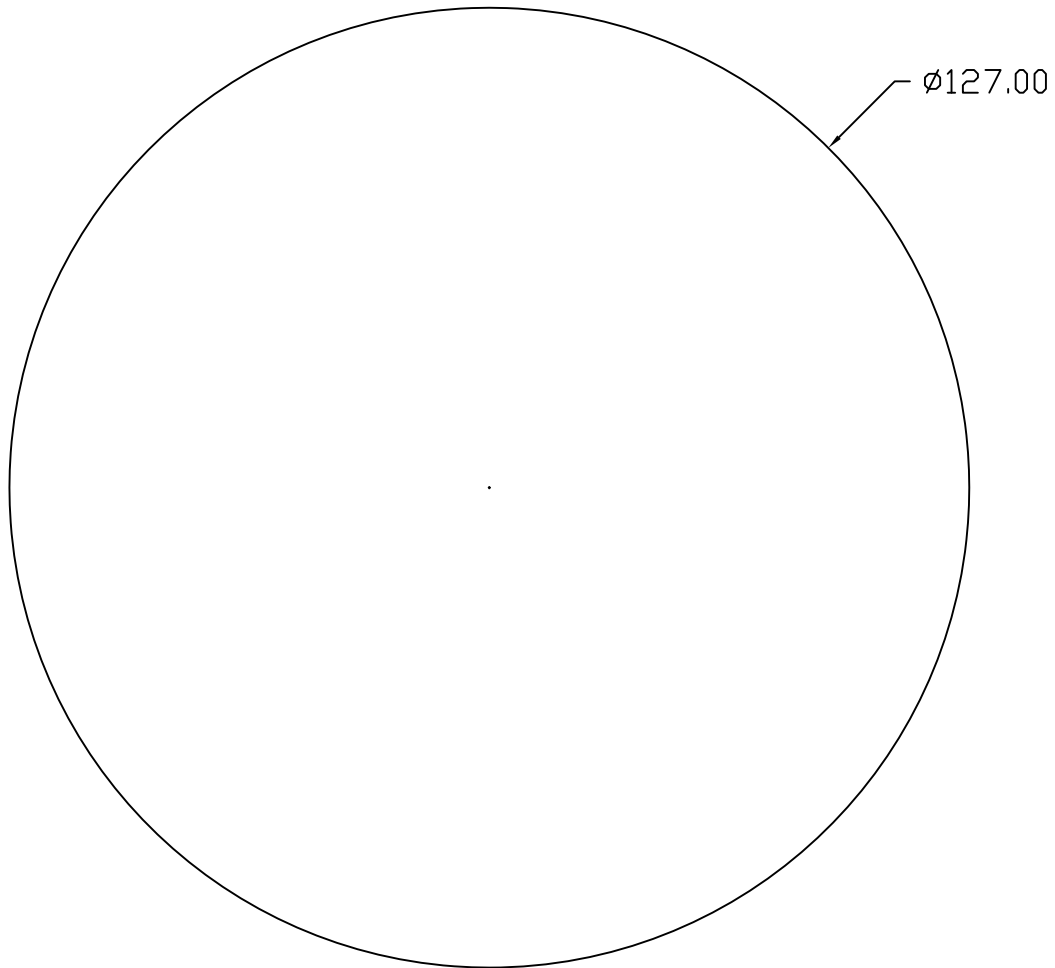

5"

Tolerance : (+ 0.3mm) (- 0 .3mm)

ALSO AVAILABLE ROUND BAR 6" , 7" , 8 " and 9"



COUNTER TRIM SECTIONS

TELS.No.7586 - 8309 ,
8990 - 7364
CP.No. 09171838309
FAX.No. 8983 - 2732

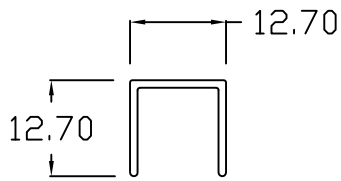

CT - 1/2 x 1/2

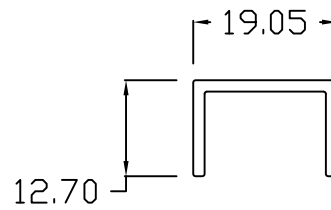

CT - 1/2 x 3/4

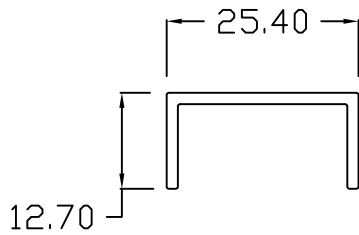

CT - 1/2 x 1

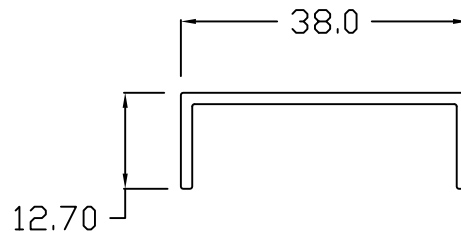

CT - 1/2 x 1 1/2

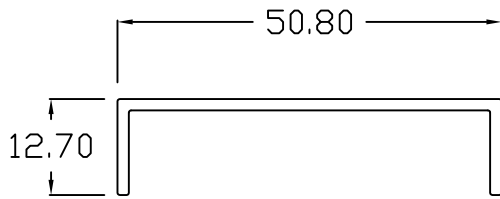

CT - 1/2 x 2

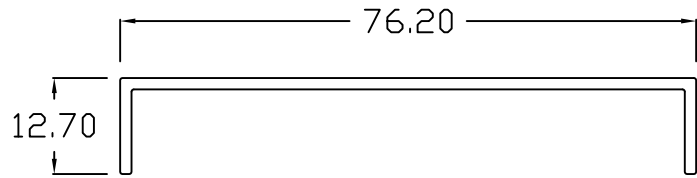

CT - 1/2 x 3

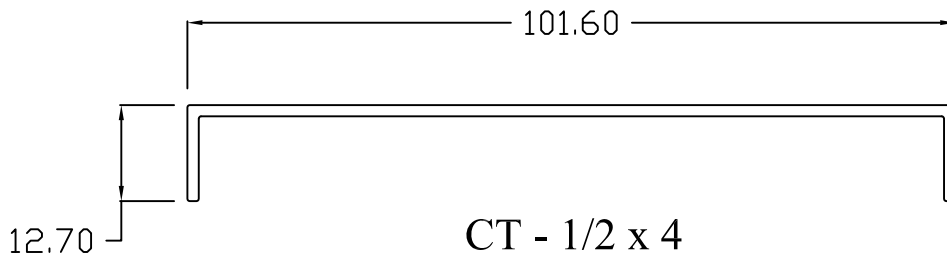

CT - 1/2 x 4



U - CHANNEL SECTIONS

TELS.No.7586 - 8309 ,
8990 - 7364
CP.No. 09171838309
FAX.No. 8983 - 2732

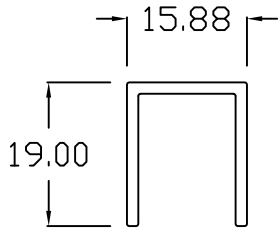

UC - 3/4 x 5/8

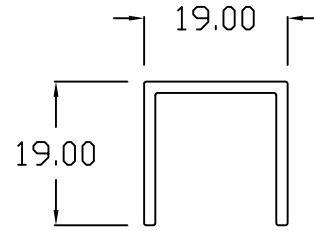

UC - 3/4 x 3/4

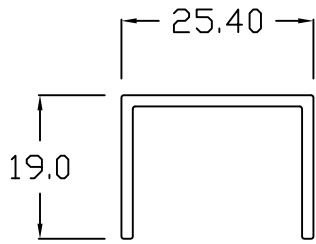

UC - 3/4 x 1

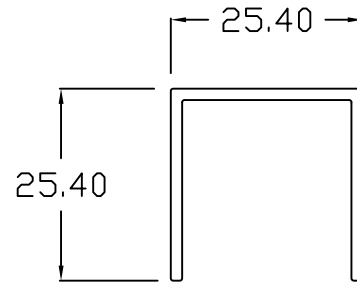

UC - 1 x 1

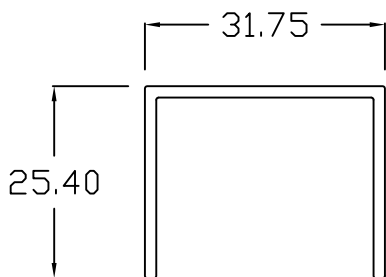

UC - 1 x 1 1/4

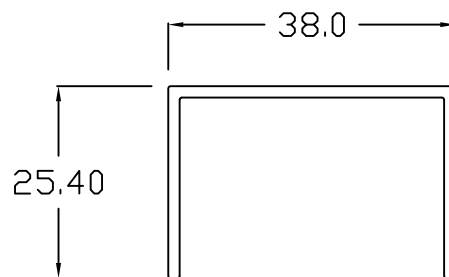

UC - 1 x 1 1/2



U - CHANNEL SECTIONS

TELS.No.7586 - 8309 ,
8990 - 7364
CP.No. 09171838309
FAX.No. 8983 - 2732

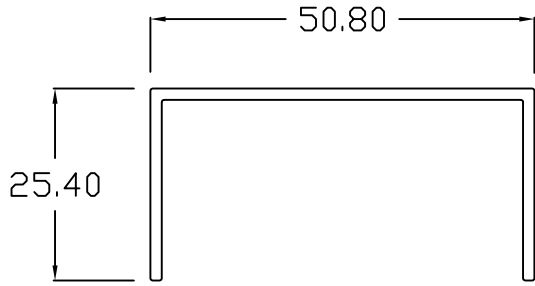

UC - 1 x 2

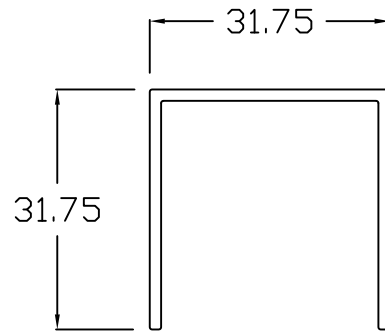

UC - 1 1/4 x 1 1/4

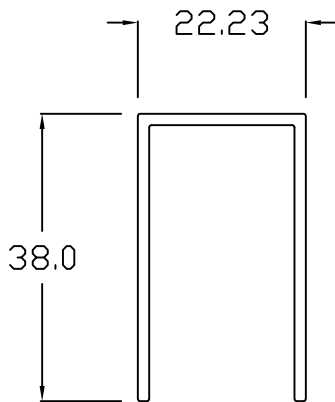

UC - 7/8 x 1 1/2

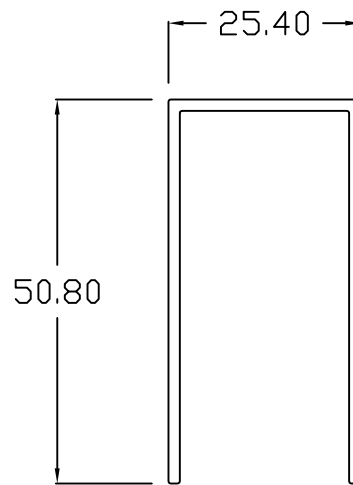

UC - 2 x 1



U - CHANNEL SECTIONS

TELS.No.7586 - 8309 ,
8990 - 7364
CP.No. 09171838309
FAX.No. 8983 - 2732

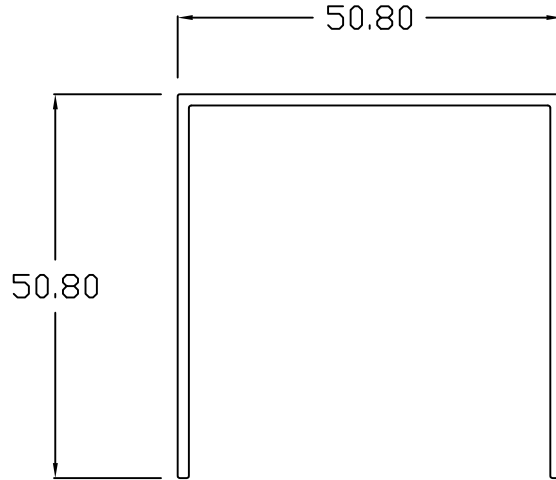

UC - 2 x 2

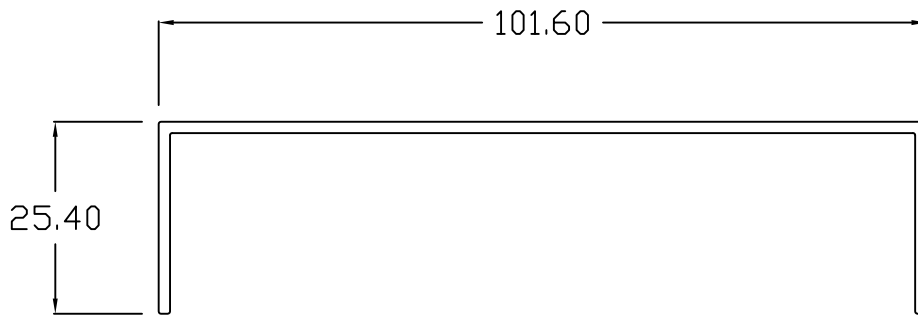

UC - 1 1/2 x 4

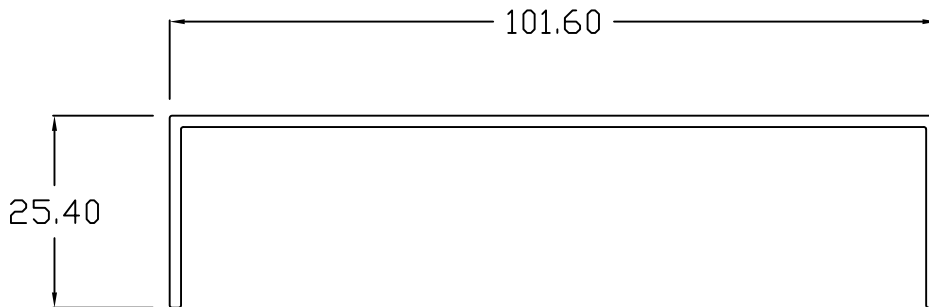

UC - 1 x 4



U - CHANNEL SECTIONS

TELS.No.7586 - 8309 ,
8990 - 7364
CP.No. 09171838309
FAX.No. 8983 - 2732

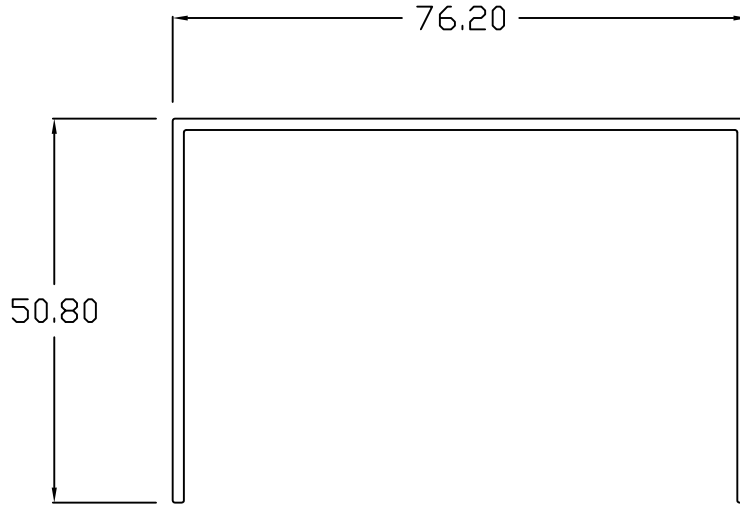

UC - 2 x 3

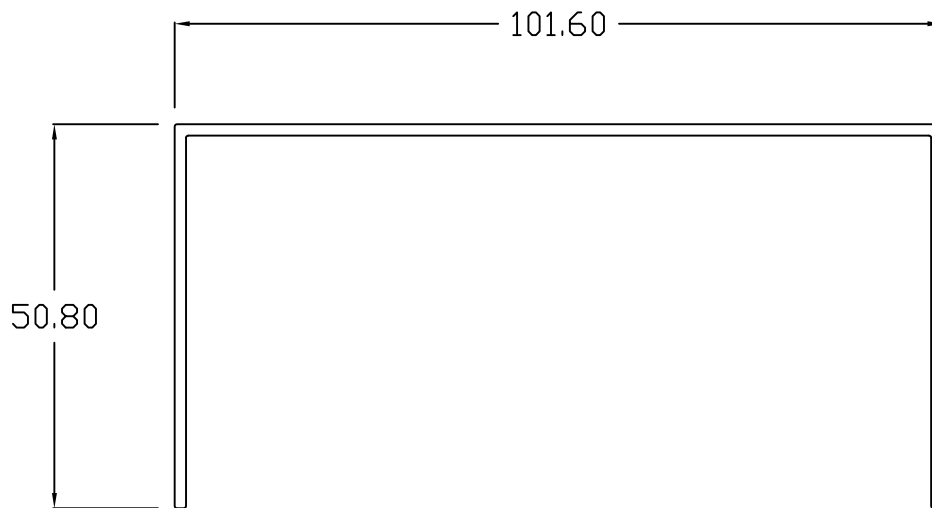

UC - 2 x 4



U - CHANNEL SECTIONS

TELS.No.7586 - 8309 ,
8990 - 7364
CP.No. 09171838309
FAX.No. 8983 - 2732

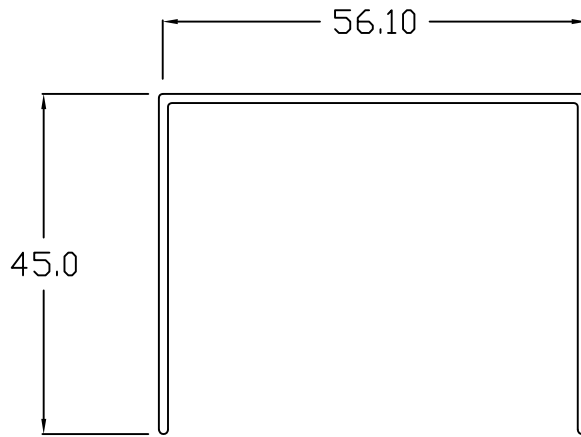

UC - 45mm x 56 mm

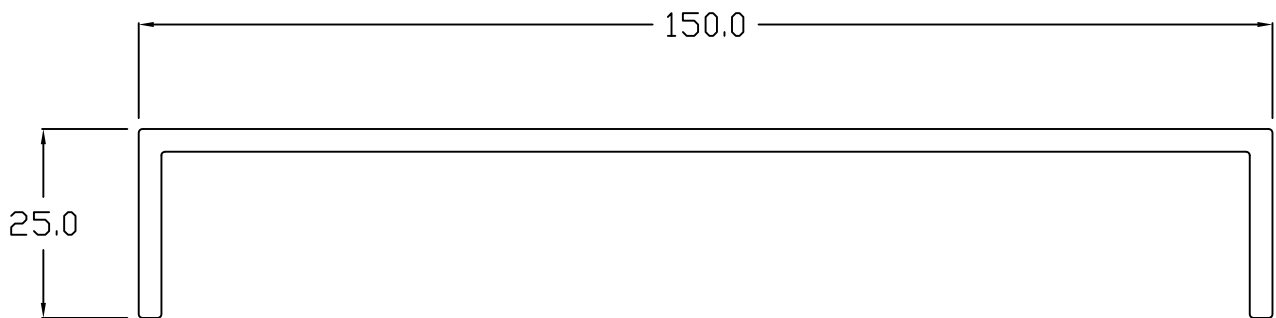

UC - 1 x 6



U - CHANNEL SECTIONS

TELS.No.7586 - 8309 ,
8990 - 7364
CP.No. 09171838309
FAX.No. 8983 - 2732

available : THICKNESS

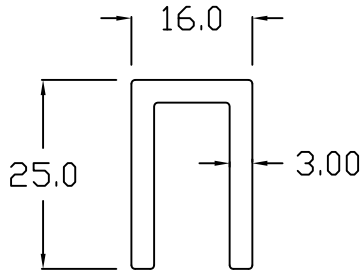

UC - 25 mm x 16 mm

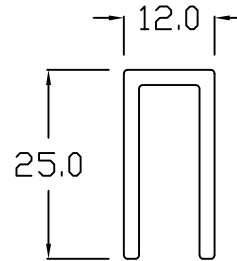

UC - 25 mm x 12 mm

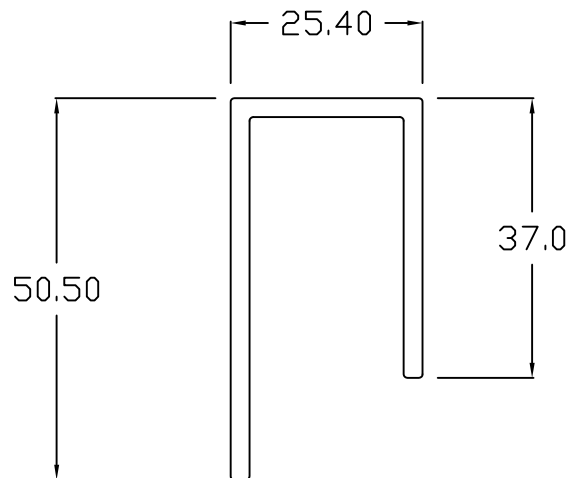

UC - 50 mm x 25 mm x 37 mm

available : 2.5mm



SPECIAL SECTIONS

TELS. 8983 - 2732 ,
3445 - 4989 ,
8990 - 7364
FAX.No. 3432 - 4324

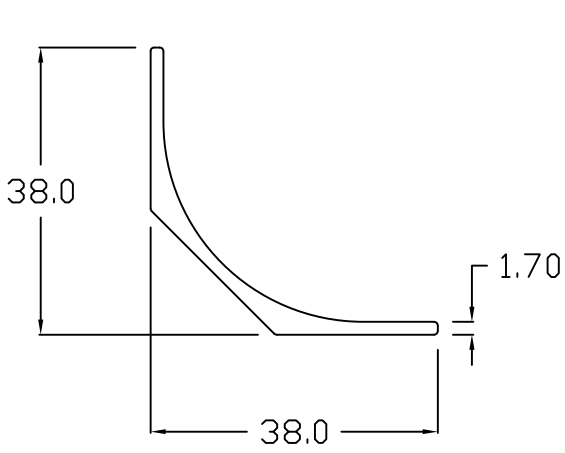

COVE RADIUS 1 1/2 "

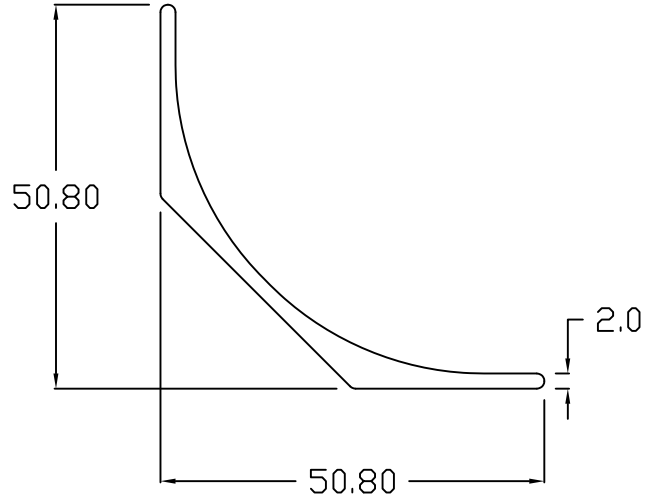

COVE RADIUS 2 "

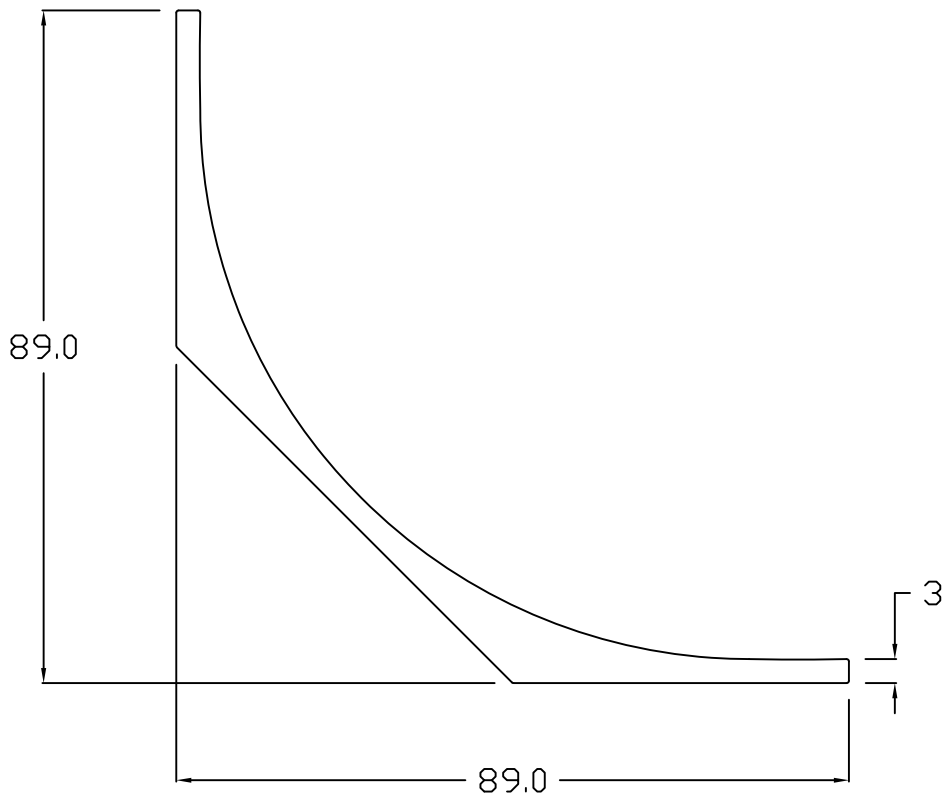

COVE RADIUS 3 1/2"



SPECIAL SECTIONS

TELS. 8983 - 2732 ,
3445 - 4989 ,
8990 - 7364
FAX.No. 3432 - 4324

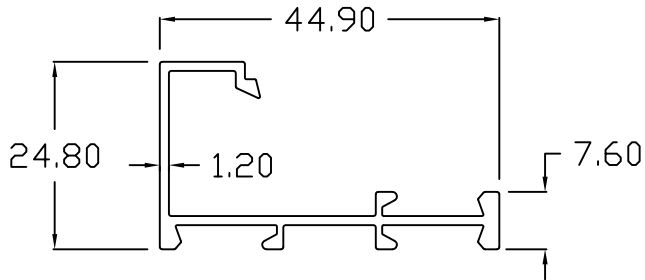

SLIM BASE

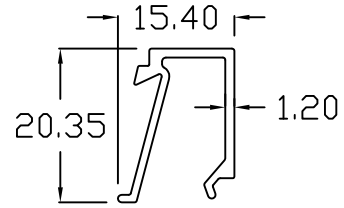

SLIM COVER

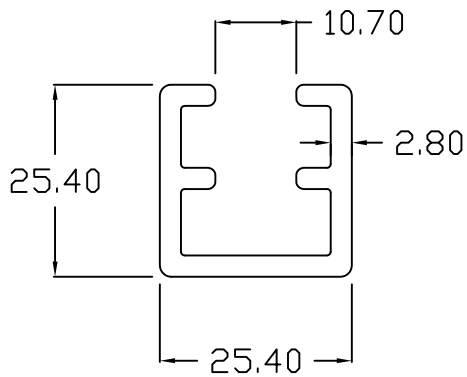

SOLAR / SIGNAGE SECTION

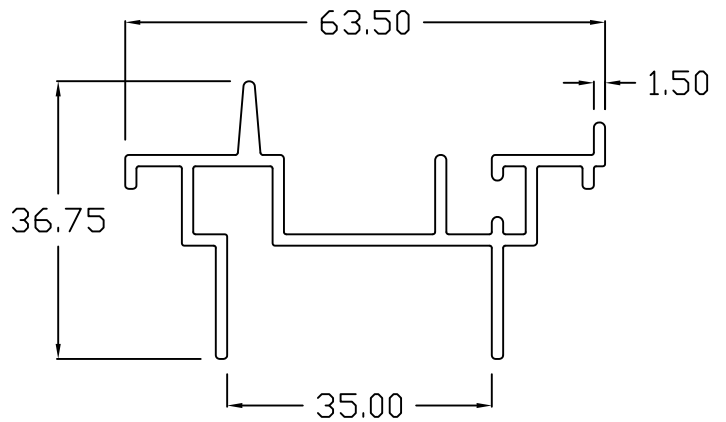

STUD

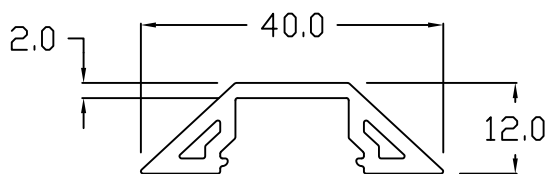

W2007A - 1

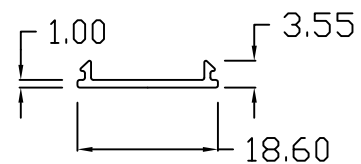

W2007A - 2



SPECIAL SECTIONS

TELS. 8983 - 2732 ,
3445 - 4989 ,
8990 - 7364
FAX.No. 3432 - 4324

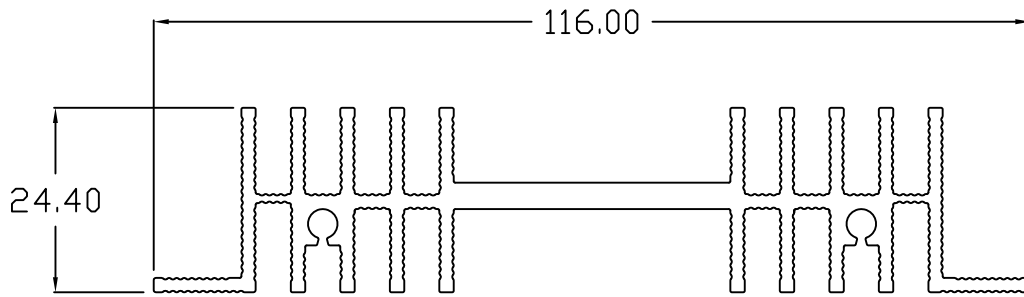

DOUBLE HEATSINK

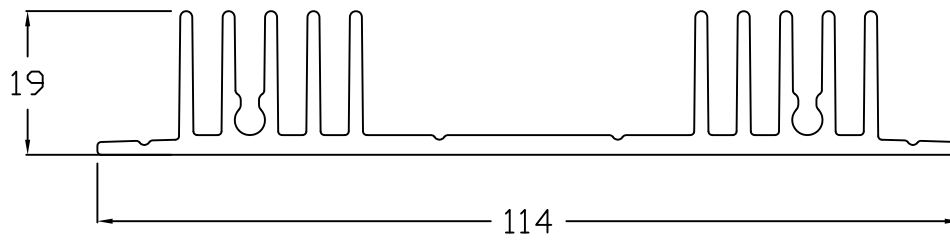

SINGLE HEATSINK



SPECIAL SECTIONS

TELS. 8983 - 2732 ,
3445 - 4989 ,
8990 - 7364
FAX.No. 3432 - 4324

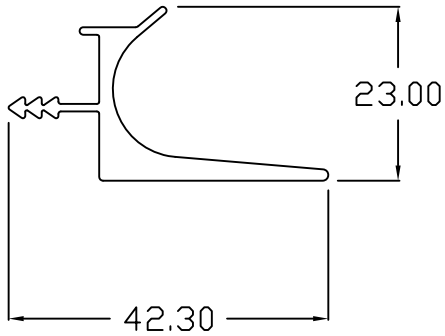

Drawer Handle Small

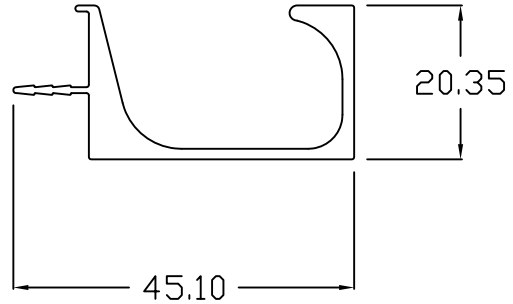

Drawer Handle Big

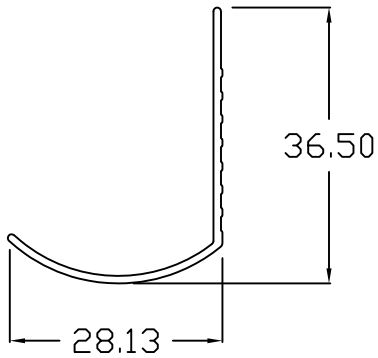

ASN 1 1/4
Stairnoising

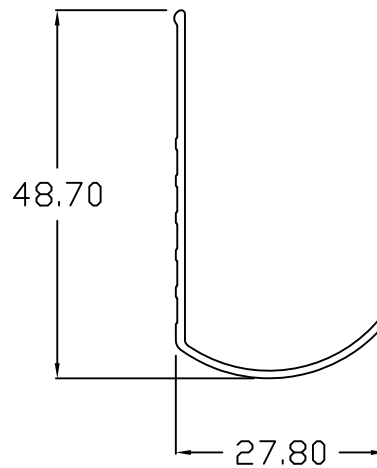

ASN 1 3/4
Stairnoising



SPECIAL SECTIONS

TELS. 8983 - 2732 ,
3445 - 4989 ,
8990 - 7364
FAX.No. 3432 - 4324

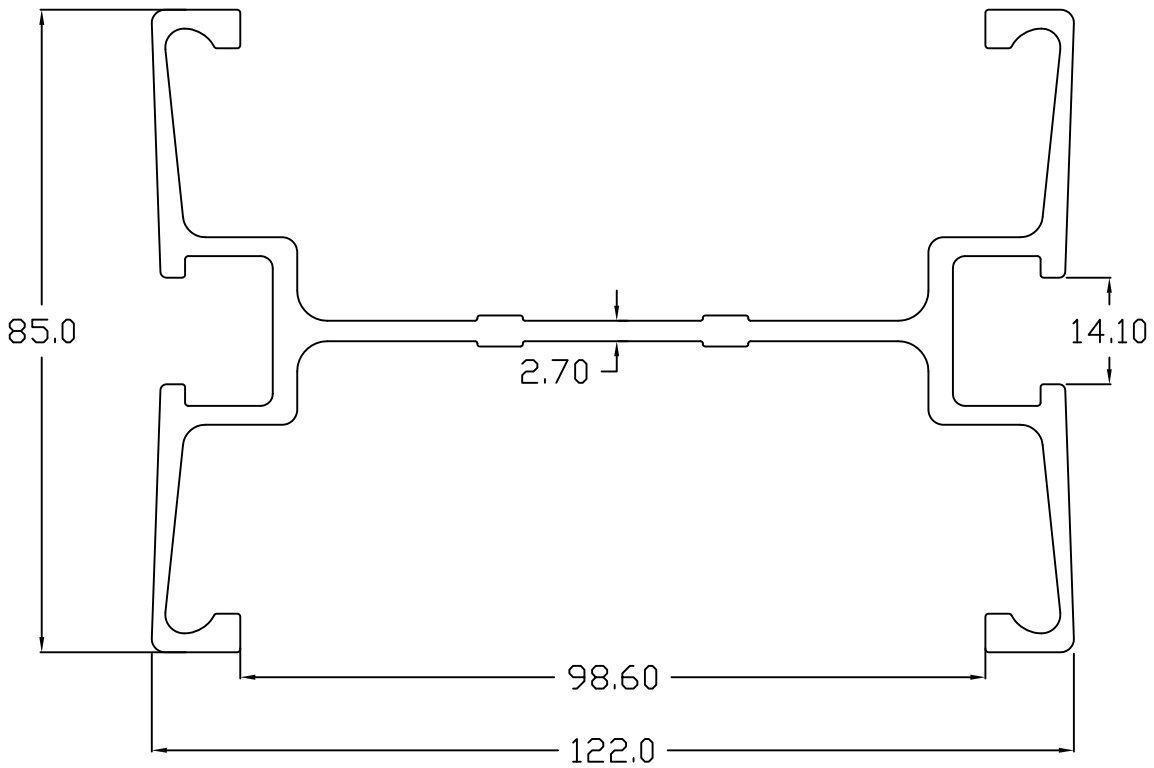
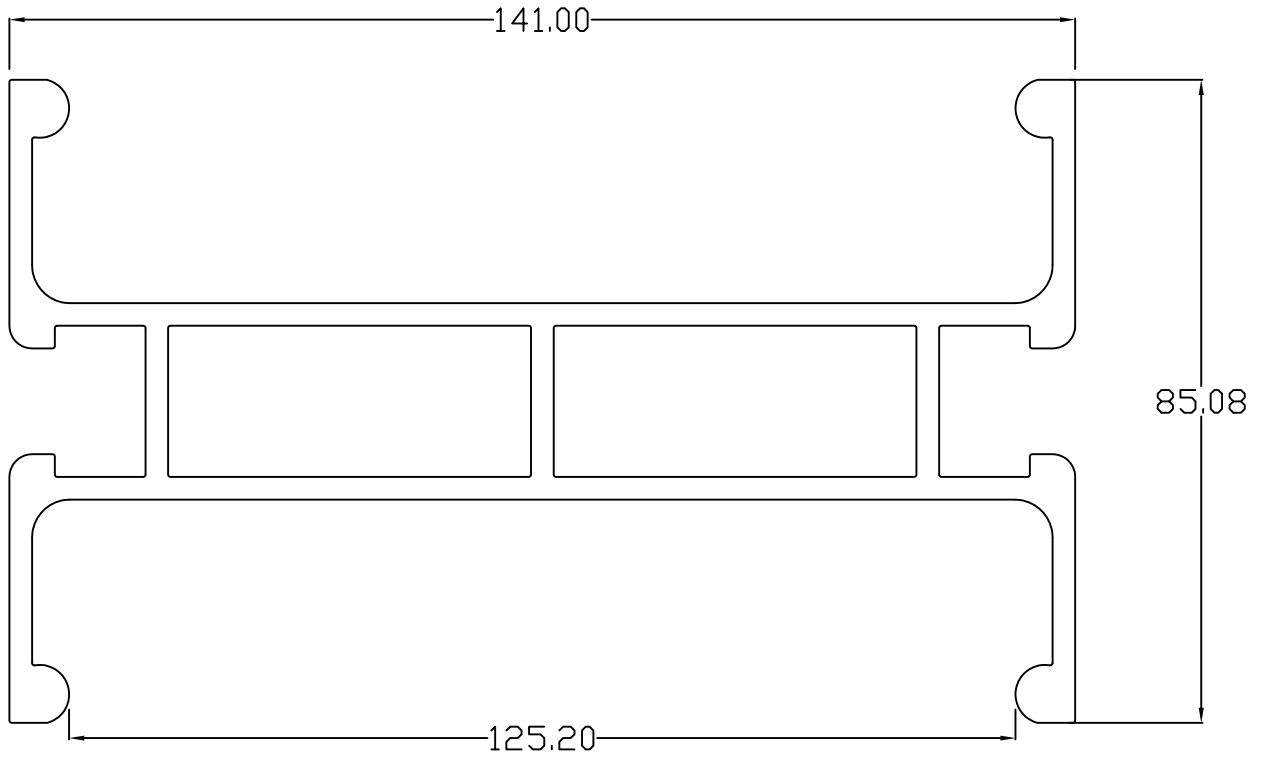



SPECIAL SECTIONS

TELS. 8983 - 2732 ,
3445 - 4989 ,
8990 - 7364
FAX.No. 3432 - 4324

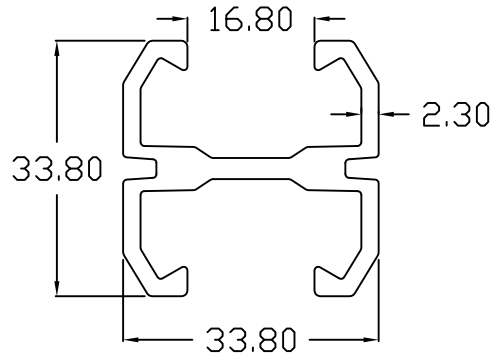

DOUBLE C

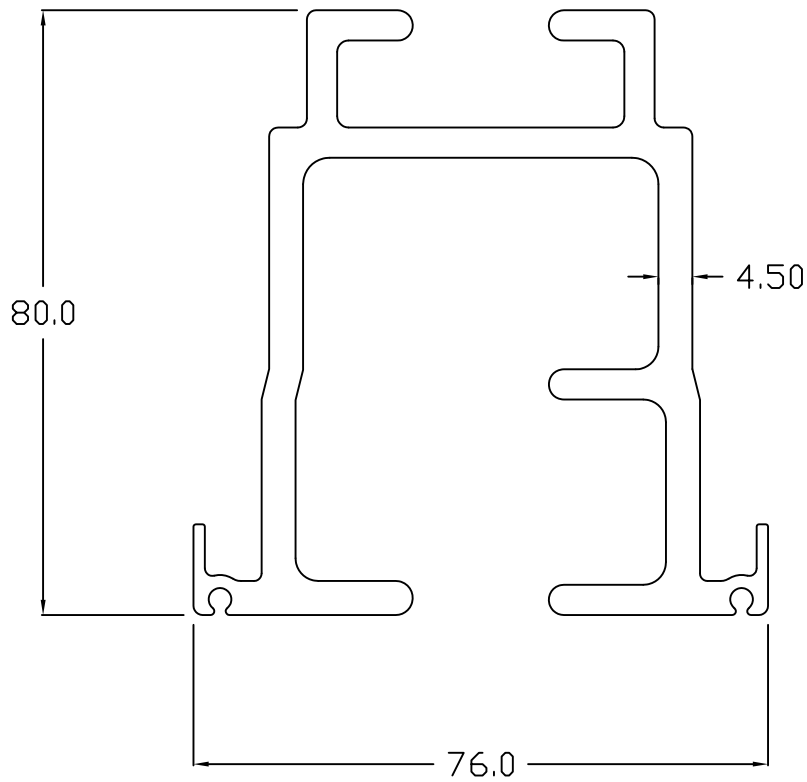

RAIL TRACK



SPECIAL SECTIONS

TELS. 8983 - 2732 ,
3445 - 4989 ,
8990 - 7364
FAX.No. 3432 - 4324

ALL SECTIONS WITH ACCESSORIES

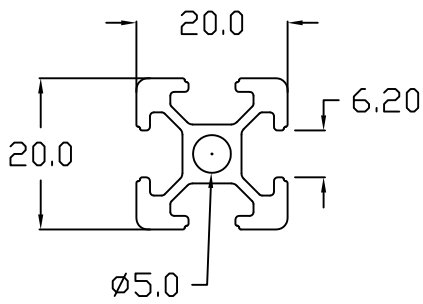

20 x 20

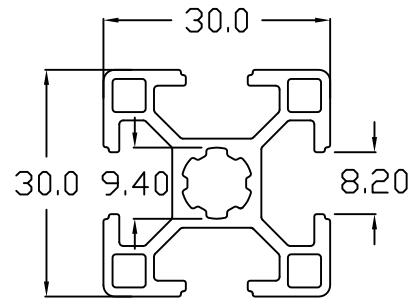

30 x 30

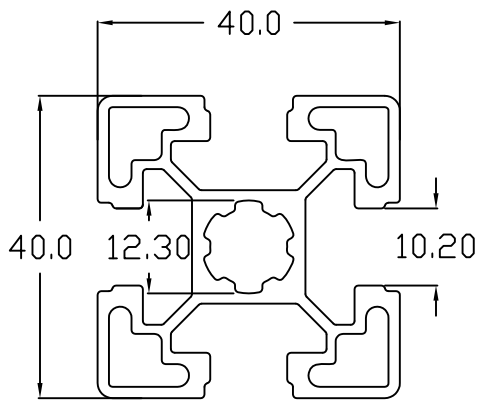

40 x 40

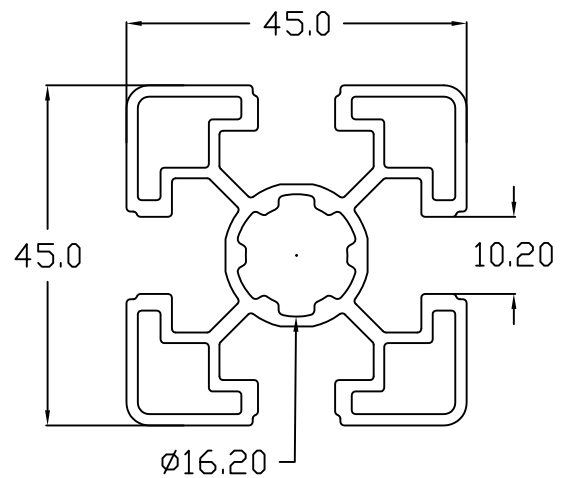

45 x 45